



TILECO INC.

PRODUCT CATALOG

91-209 Hanua Street | Kapolei, Hawaii 96707
Phone: (808) 682-5737 | Fax: (808) 682-1013
Email: info@tilecoinc.com | www.tilecoinc.com



PRODUCT CATALOG

TABLE OF CONTENTS

CONCRETE MASONRY

Standard Units	p. 3-11
4" Concrete Masonry Units.....	3
6" Concrete Masonry Units.....	4
8" Concrete Masonry Units.....	5-7
10" Concrete Masonry Units.....	8
12" Concrete Masonry Units.....	9-10
Column & Pilaster.....	11

Accessory Units	p. 12-15
Bricks.....	12
Dobies.....	12
Foundation Block.....	12
Garage Pier.....	12
Screen Block.....	14-15
Termite Block.....	12
Window Sills.....	13

Architectural Units	p. 16-24
1 Score.....	19
3U Fluted Split.....	21
3V Fluted Split.....	21
5 Score.....	19
7V Fluted Split.....	22
Bullnose.....	23
Ground Face.....	24
Shadowcaster.....	20
Split Face.....	16-18
4".....	16
6".....	16
8".....	17
10".....	18
12".....	18
Tapestry.....	23

GARDEN PRODUCTS	p. 25-27
Arborstone Garden Wall Units.....	25
Cobblestone.....	26
Garden Edgers.....	25
Grass Block.....	27
Pavers.....	26
Patio Blocks.....	27

KEYSTONE RETAINING WALL UNITS	p. 28-29
Compac I.....	28
Compac III.....	28
Mini.....	28
Standard I.....	28
Standard III.....	28
Victorian Stone.....	28
Caps.....	29
Corner Unit.....	29

TILECO MORTARLESS INTERLOCKING UNITS	30
--------------------------------------	----

SOLAR BALLAST BLOCK	31
---------------------	----

STANDARD UNITS: 4" Standard Concrete Masonry Units

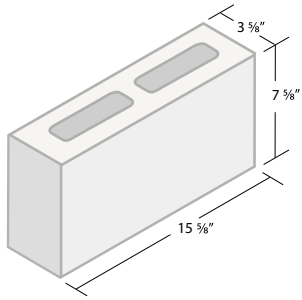

4 x 8 x 16 Partition
ITEM #048P

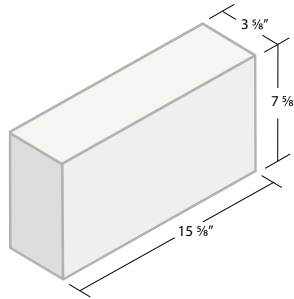

4 x 8 x 16 Partition Solid**
ITEM #048BA

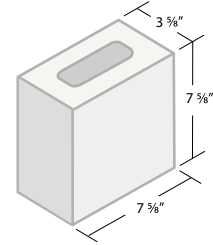

4 x 8 x 8 Half
ITEM #048H

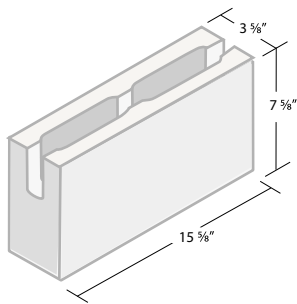

4 x 8 x 16 Bond Beam
ITEM #048K

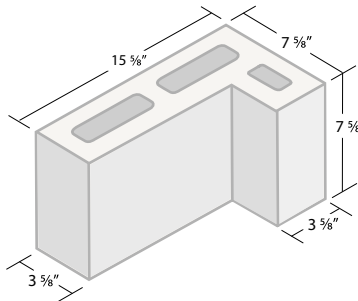

4 x 8 x 16 L-Return
ITEM #048L

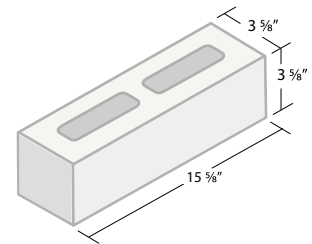

4 x 4 x 16 DSE
ITEM #044D

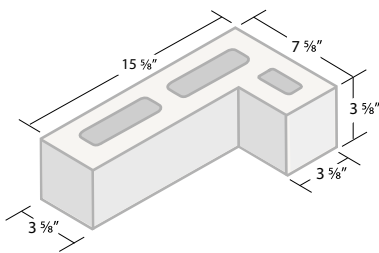

4 x 4 x 16 L-Return
ITEM #044L

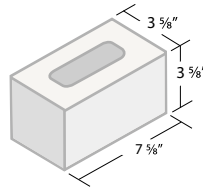

4 x 4 x 8 Half
ITEM #044H

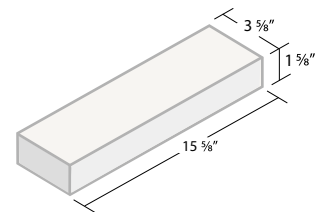

4 x 2 x 16 Cap
ITEM #042

** Special order. Lead time and additional charges may apply.

STANDARD UNITS: 6" Concrete Masonry Units

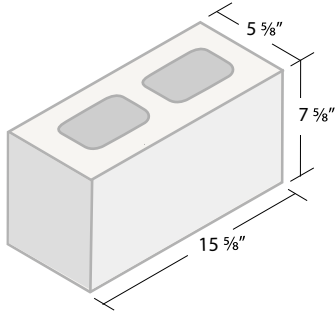

**6 x 8 x 16
Double Solid End**
ITEM #068D

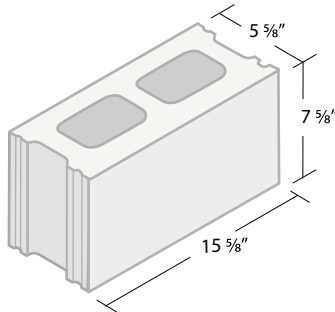

6 x 8 x 16 Runner
ITEM #068M

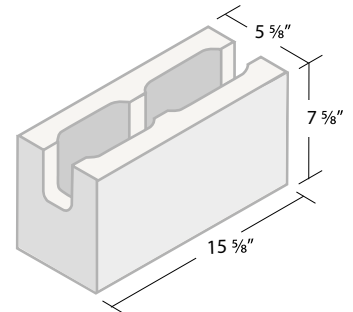

6 x 8 x 16 Bond Beam
ITEM #068K

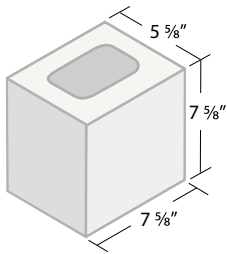

6 x 8 x 8 Half
ITEM #068H

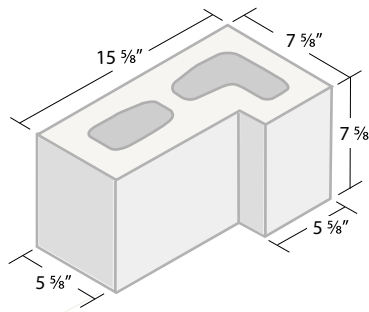

6 x 8 x 16 L-Return
ITEM #068L

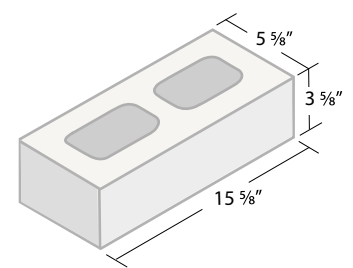

**6 x 4 x 16
Double Solid End**
ITEM #064D

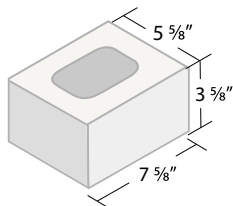

6 x 4 x 8 Half
ITEM #064H

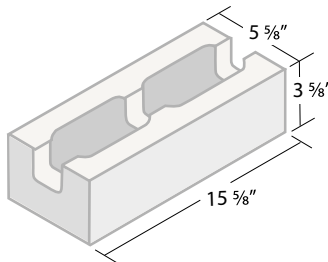

6 x 4 x 16 Bond Beam*
ITEM #064K

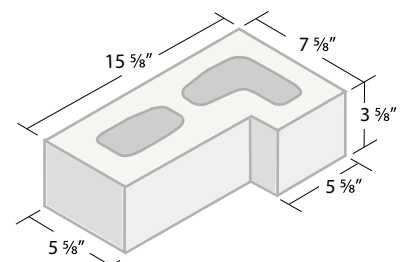

6 x 4 x 16 L-Return
ITEM #064L

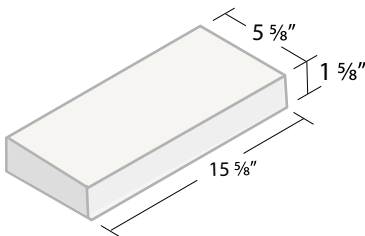

6 x 2 x 16 Cap
ITEM #062

*May require lead time. Call for availability.

STANDARD UNITS: 8" Concrete Masonry Units

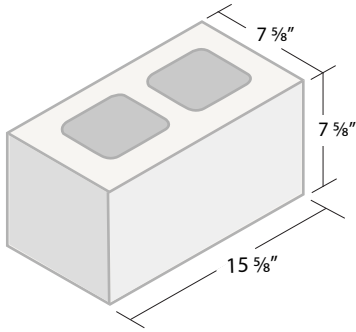

8 x 8 x 16 Double Solid End
ITEM #088D

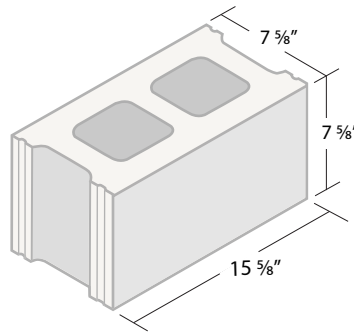

8 x 8 x 16 Runner
ITEM #088M

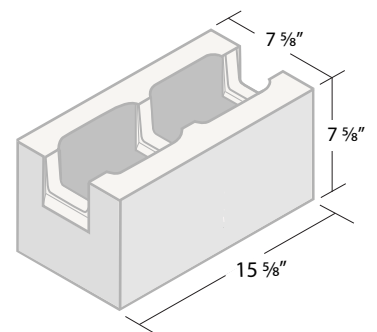

8 x 8 x 16 Bond Beam
ITEM #088K

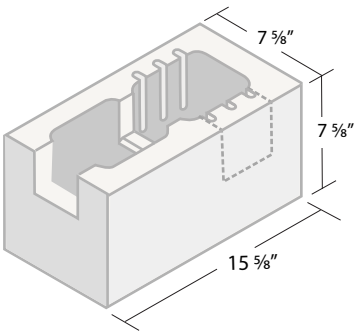

8 x 8 x 16 Corner Knock-Out
ITEM #088CKO

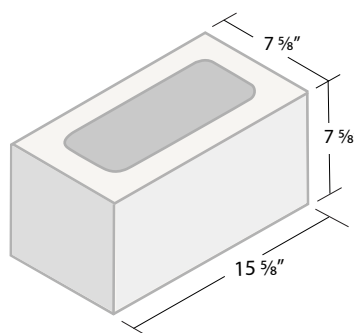

8 x 8 x 16 Webless
ITEM #088W

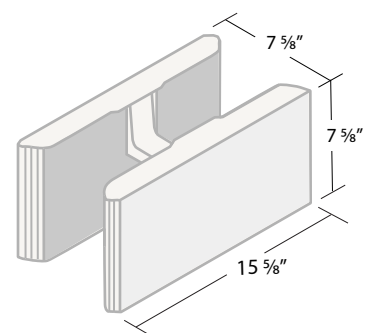

8 x 8 x 16 Grout Lock
ITEM #088GL

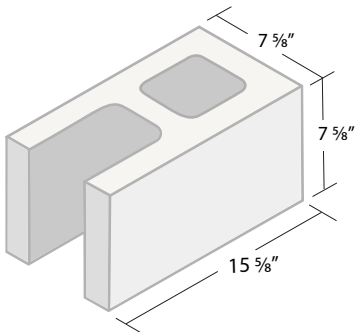

8 x 8 x 16 Plumber
ITEM #088P

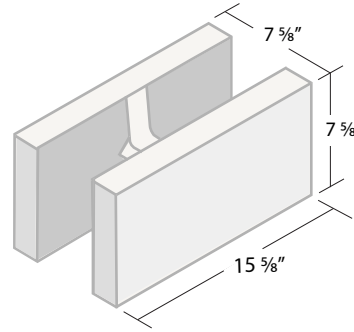

8 x 8 x 16 Double Open End
ITEM #088DOE

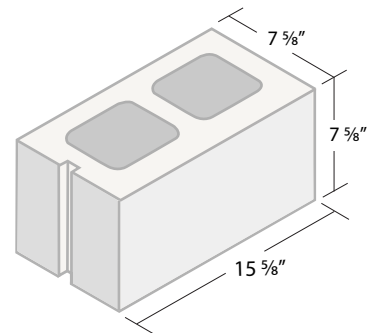

8 x 8 x 16 Jamb
ITEM #088J

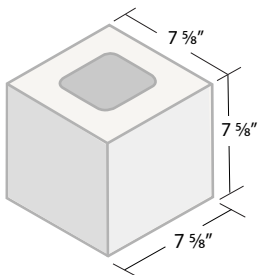

8 x 8 x 8 Half
ITEM #088H

STANDARD UNITS: 8" Concrete Masonry Units

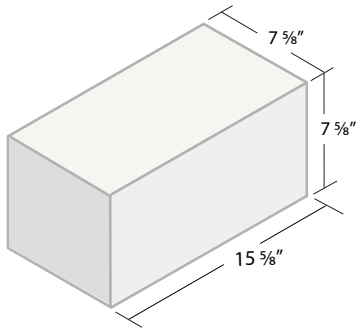

8 x 8 x 16 Ballast**
ITEM #088BL

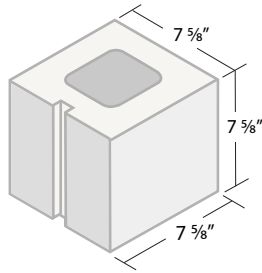

8 x 8 x 8 Jamb Half
ITEM #088JH

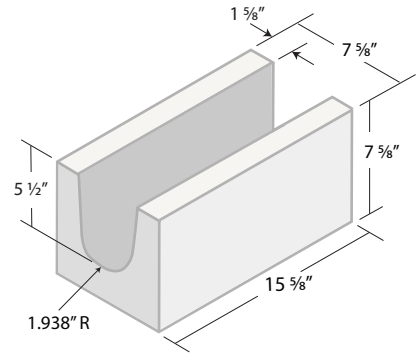

8 x 8 x 16 Lintel*
ITEM #088LT

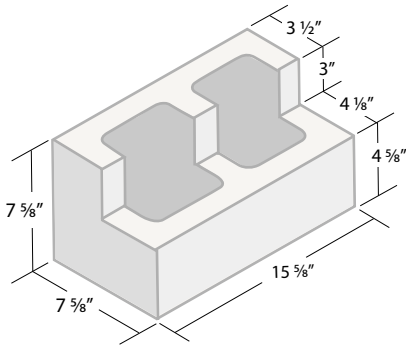

8 x 8 x 16 Header
ITEM #088HD

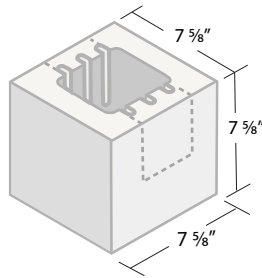

8 x 8 x 8 Knock Out Half
ITEM #088KOH

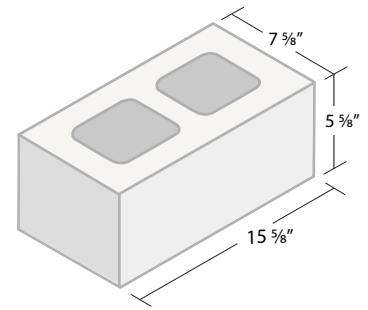

8 x 6 x 16 DSE
ITEM #086D

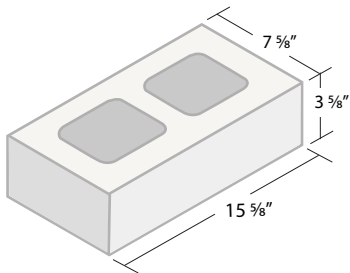

8 x 4 x 16 DSE
ITEM #084D

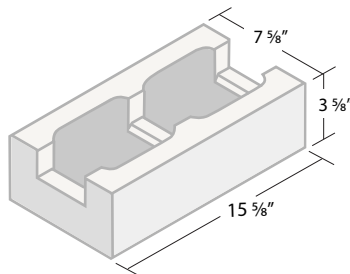

8 x 4 x 16 Bond Beam
ITEM #084K

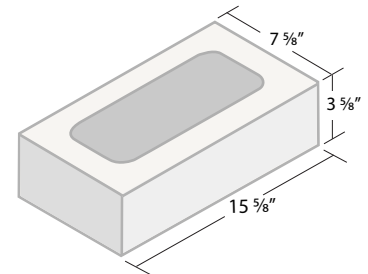

8 x 4 x 16 Webless
ITEM #084W

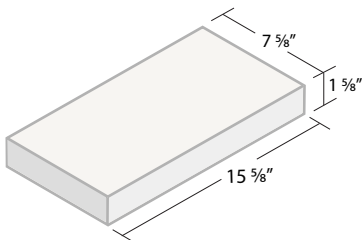

8 x 2 x 16 Cap
ITEM #082

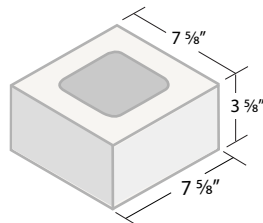

8 x 4 x 8 Half
ITEM #084H

STANDARD UNITS: 8" Concrete Masonry Units

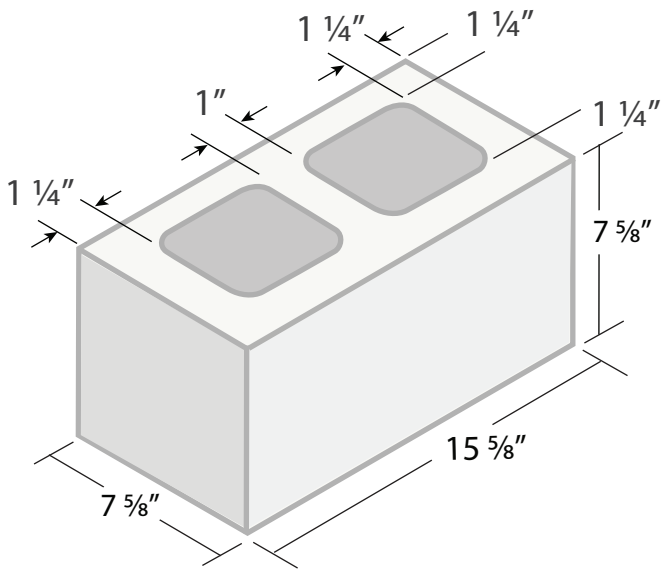

TOP VIEW

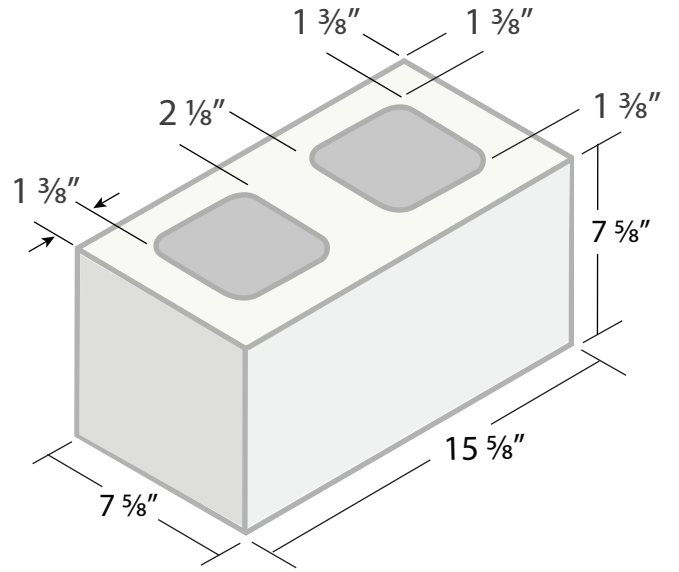

BOTTOM VIEW

8 x 8 x 16 Double Solid End

STANDARD UNITS: 10" Standard Concrete Masonry Units

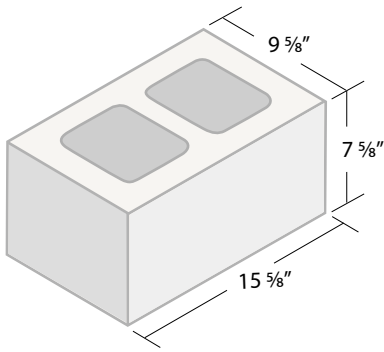

10 x 8 x 16 Double Solid End
ITEM #108D

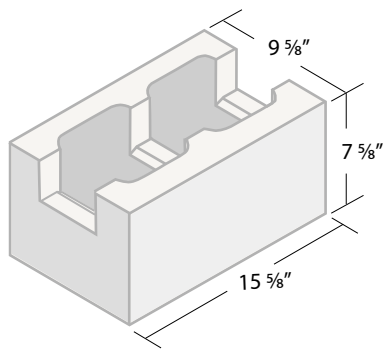

10 x 8 x 16 Bond Beam
ITEM #108K

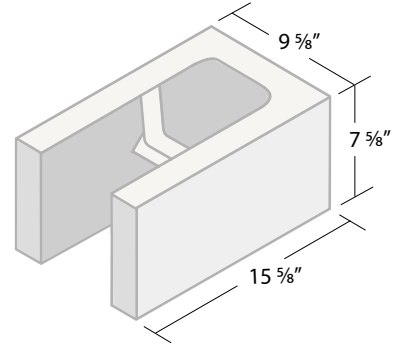

10 x 8 x 16 Single Open End*
ITEM #108SOE

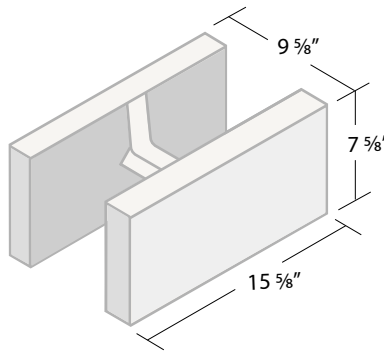

10 x 8 x 16 Double Open End*
ITEM #108DOE

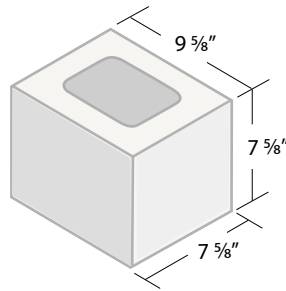

10 x 8 x 8 Half
ITEM #108H

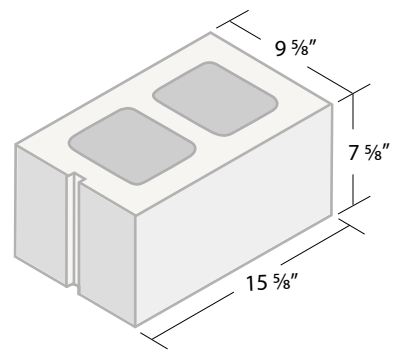

10 x 8 x 16 Jamb*
ITEM #108J

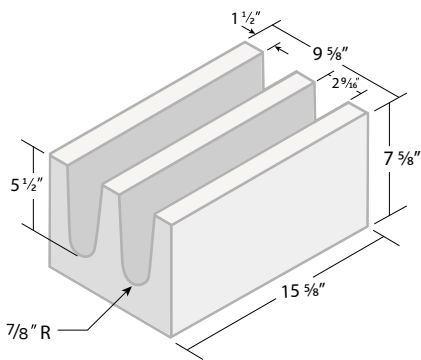

10 x 8 x 16 Lintel**
ITEM #108LT

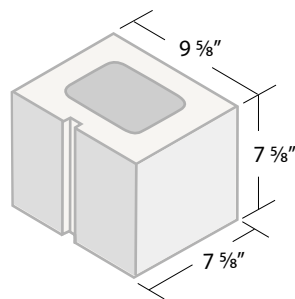

10 x 8 x 8 Jamb Half*
ITEM #108HJ

STANDARD UNITS: 12" Concrete Masonry Units

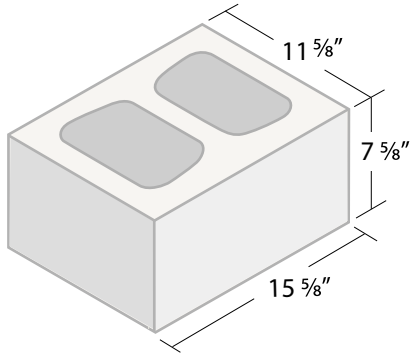

12 x 8 x 16 Double Solid End
ITEM #128D

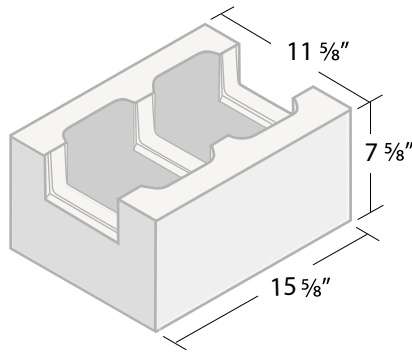

12 x 8 x 16 Bond Beam
ITEM #128K

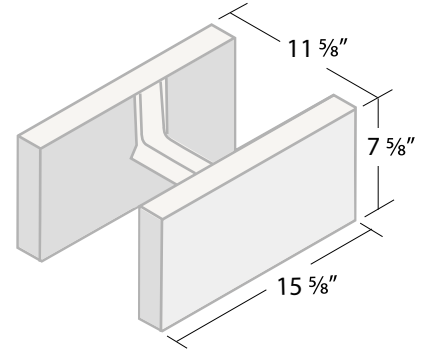

12 x 8 x 16 Double Open End
ITEM #128DOE

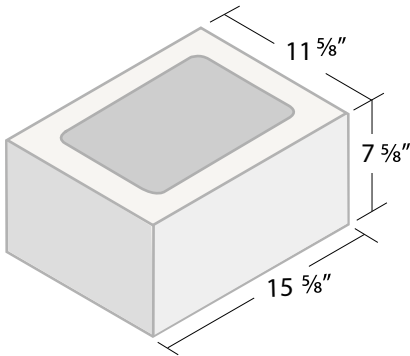

12 x 8 x 16 Webless
ITEM #128W

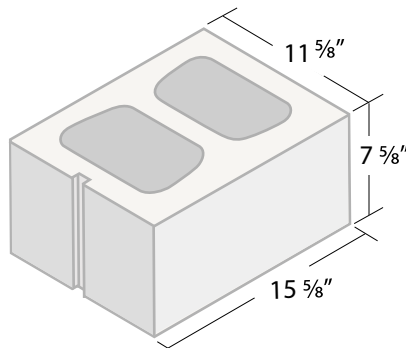

12 x 8 x 16 Jamb*
ITEM #128J

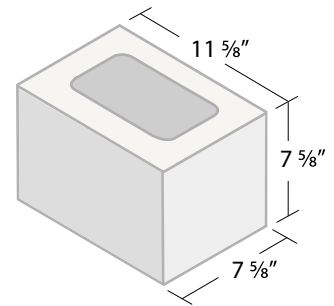

12 x 8 x 8 Half
ITEM #128H

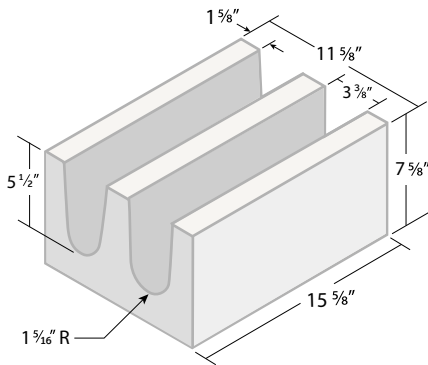

12 x 8 x 16 Lintel**
ITEM #128LT

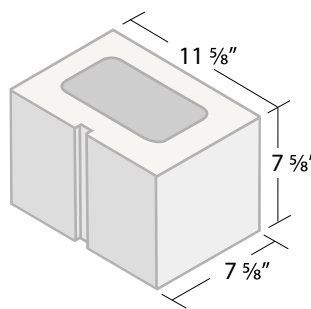

12 x 8 x 8 Jamb Half*
ITEM #128JH

STANDARD UNITS: 12" Concrete Masonry Units

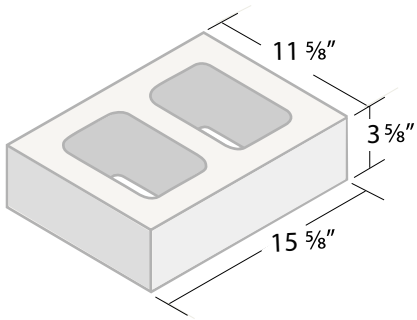

12 x 4 x 16 Double Solid End*
ITEM #124D

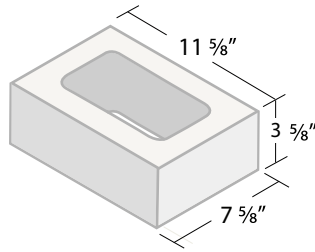

12 x 4 x 8 Half*
ITEM #124H

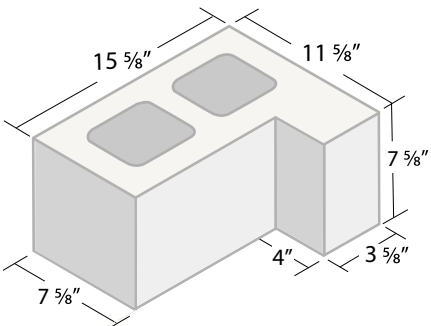

12 x 8 x 16 L-Return
ITEM #128L

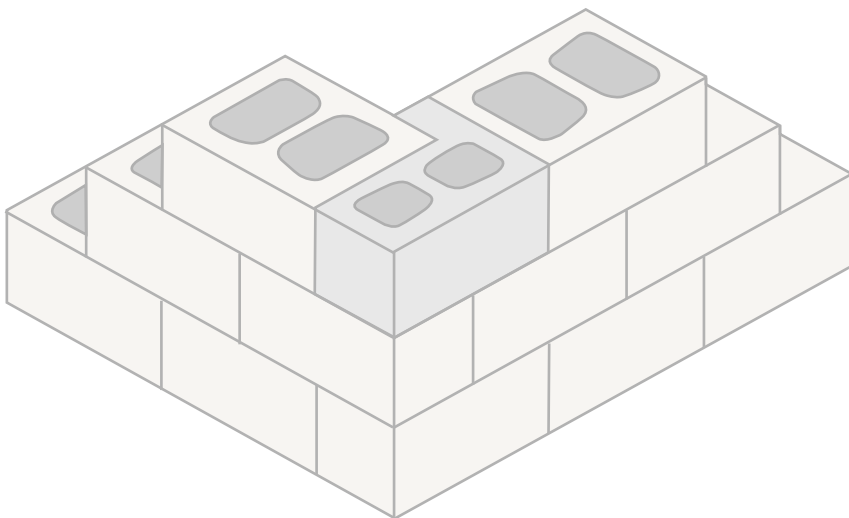
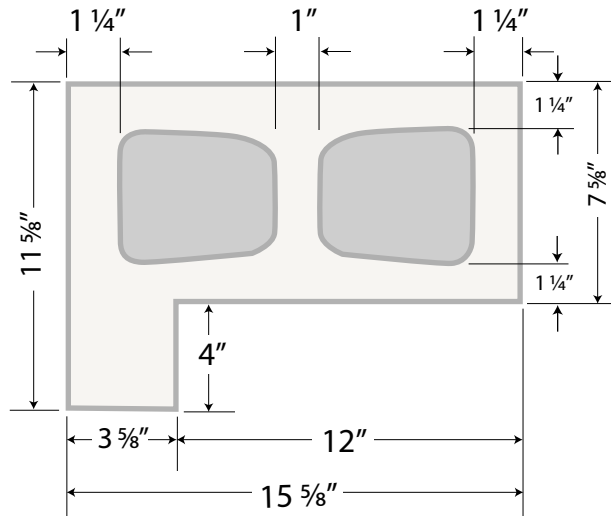

STANDARD UNITS: Column & Pilaster Concrete Masonry Units

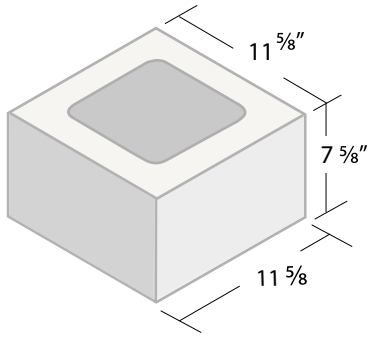

12 x 8 x 12 Column
ITEM #128C

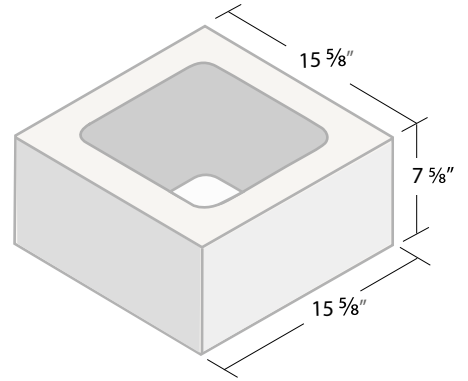

16 x 8 x 16 Column
ITEM #168C

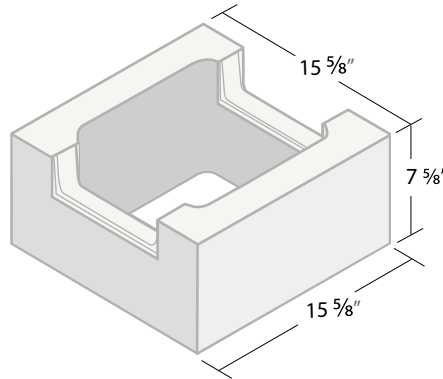

16 x 8 x 16 Bond Beam**
ITEM #168K

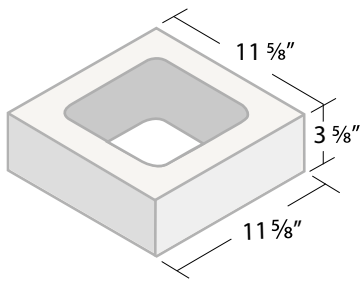

12 x 4 x 12 Column*
ITEM #124C

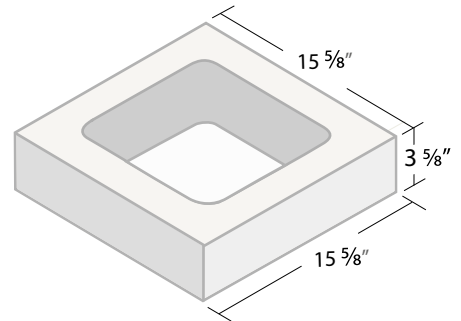

16 x 4 x 16 Column*
ITEM #164C

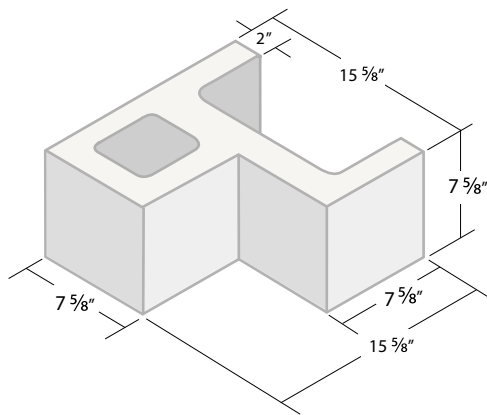

8" H Pilaster
ITEM #8HP

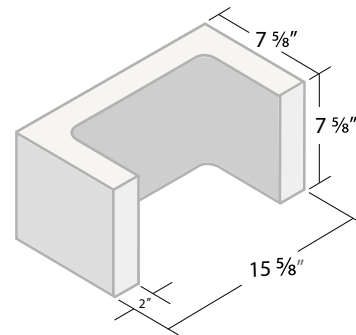

8" C Pilaster
ITEM #8CP

* May require lead time. Call for availability.

** Special Order. Lead time and additional charges may apply.

ACCESSORY UNITS

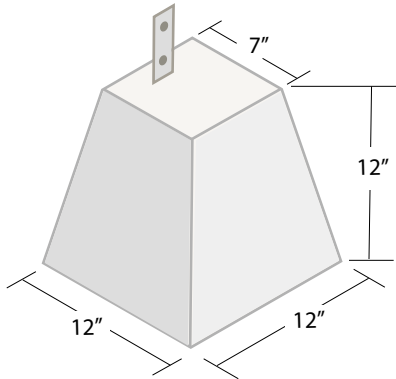

**12" Garage Pier
with Strap**
ITEM #127GPS

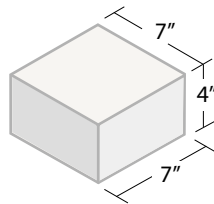

**7 x 4 x 7
Termite Block**
ITEM #074T

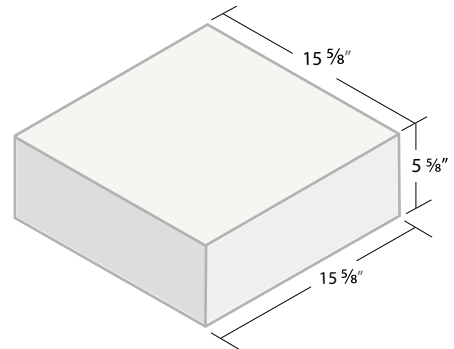

**16 x 6 x 16
Foundation Block**
ITEM #166F

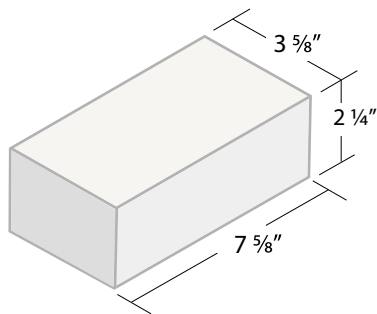

2 x 4 x 8 Brick
Buff Brick: ITEM #024B
Red Brick: ITEM #024RB
Basalt Brick: ITEM #024BSB

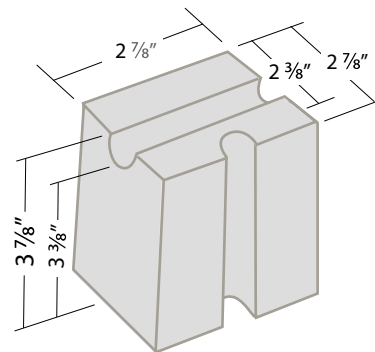

Dobies
ITEM #DOBI5

WINDOW SILL BLOCKS

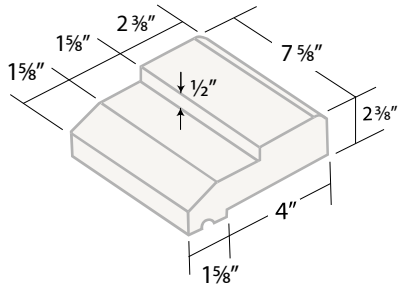

4" Window Sill

ITEM #4WS

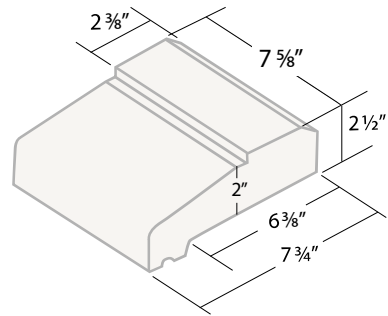

6" Window Sill

ITEM #6WS

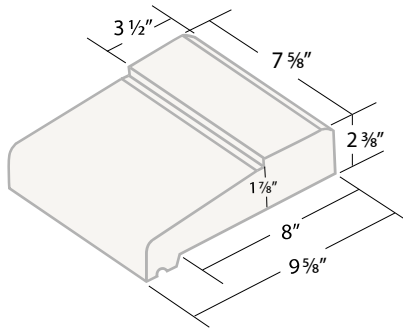

8" Window Sill J-1

ITEM #81WS

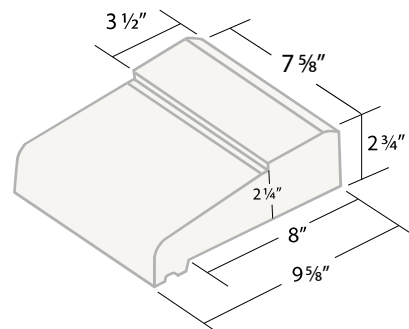

8" Window Sill J-2

ITEM #82WS

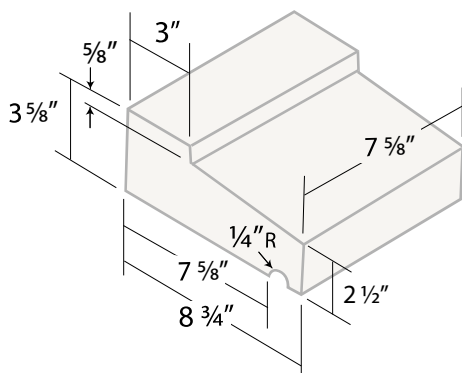

9" Window Sill J-3

ITEM #9WS

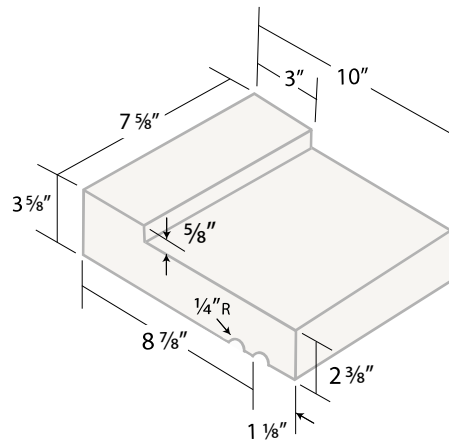

10" Window Sill J-4

ITEM #10WS

ACCESSORY UNITS: Screen Block

#377
Screen Block
4 x 12 x 12

ITEM #4S377

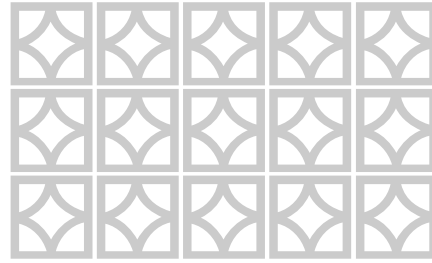
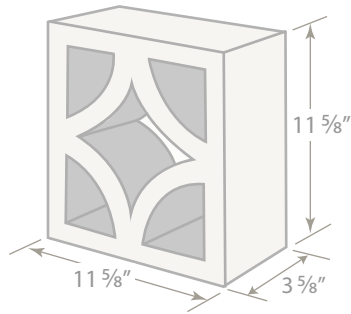

#399
Screen Block
4 x 12 x 12

ITEM #4S399

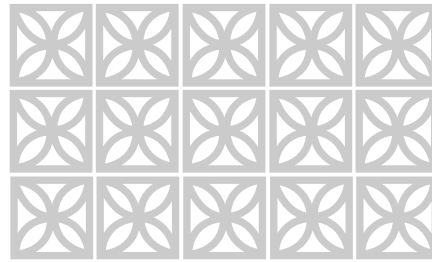
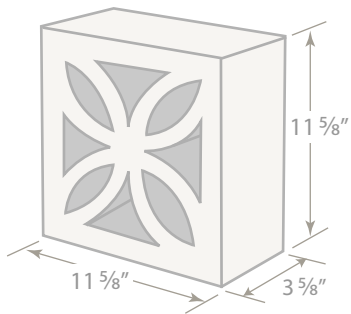

#397
Screen Block
4 x 12 x 12

ITEM #4S397

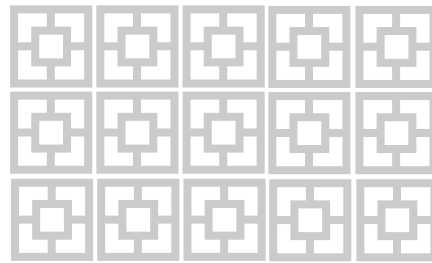
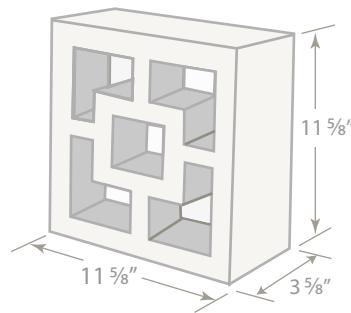

#1086
Screen Block
4 x 12 x 12

ITEM #4S1086

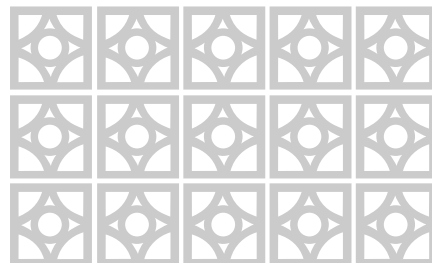
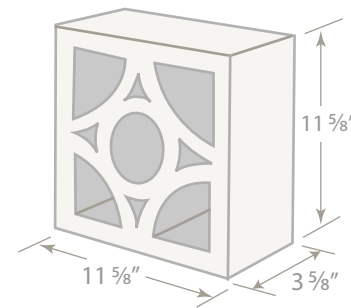

ACCESSORY UNITS: Screen Block

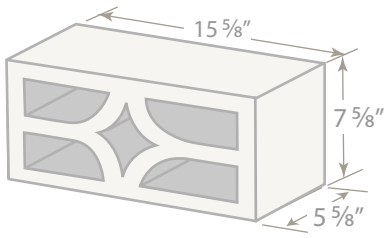

#422
6" Screen Block
6 x 8 x 16
 ITEM #6S422

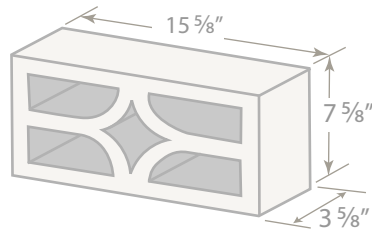

#422
4" Screen Block
4 x 8 x 16
 ITEM #4S422

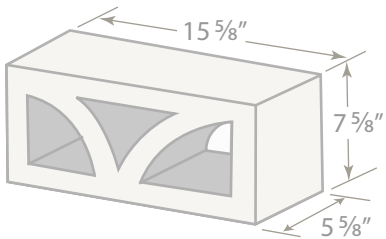
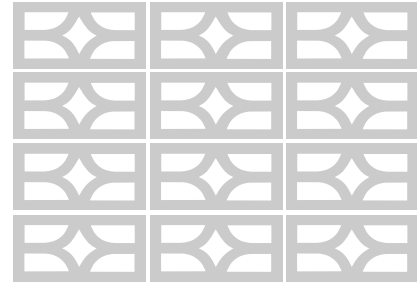

#414
6" Screen Block
6 x 8 x 16
 ITEM #6S414

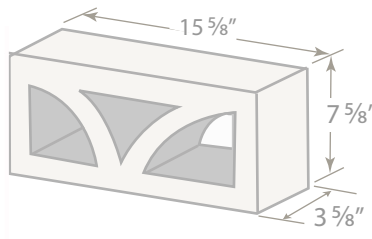

#414
4" Screen Block
4 x 8 x 16
 ITEM #4S414

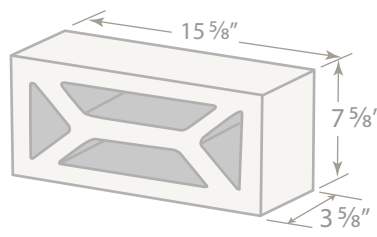
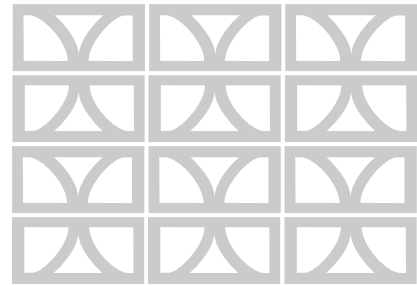

#314
4" Screen Block
4 x 8 x 16
 ITEM #4S314

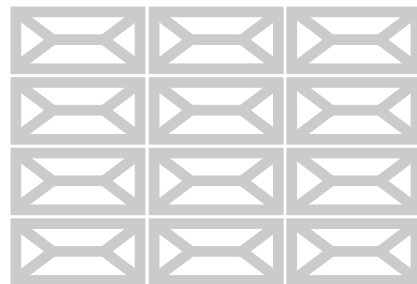

ARCHITECTURAL UNITS: 4" & 6" Split Face

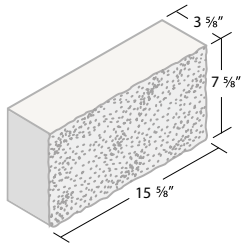

**4 x 8 x 16 Split (Solid)
1 Face Veneer****

ITEM #048S

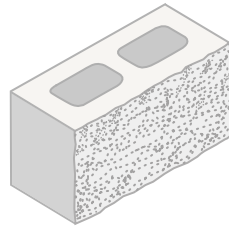

**6 x 8 x 16 Split
1 Face**

ITEM #068S

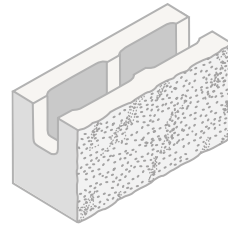

**6 x 8 x 16 Split
Bond Beam, 1 Face**

ITEM #068SK

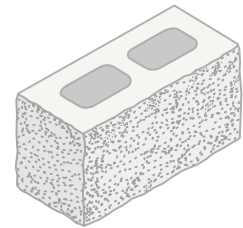

**6 x 8 x 16 Split
1 Face / 1 End***

ITEM #068SFE

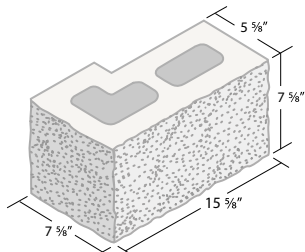

**6 x 8 x 16 Split
L-Return**

ITEM #068SL

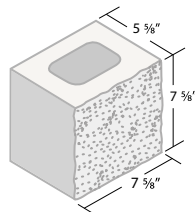

**6 x 8 x 8 Split
Half, 1 Face***

ITEM #068SH

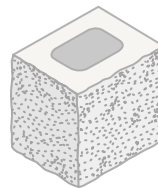

**6 x 8 x 8 Split
Half, 1 Face / 1 End***

ITEM #068SFEH

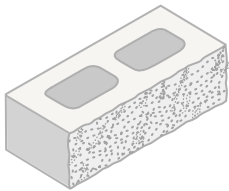

**6 x 4 x 16 Split
1 Face**

ITEM #064S

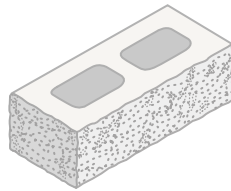

**6 x 4 x 16 Split
1 Face / 1 End***

ITEM #064SFE

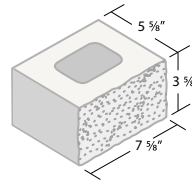

**6 x 4 x 8 Split
Half, 1 Face***

ITEM #064SH

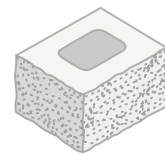

**6 x 4 x 8 Split
Half, 1 Face / 1 End***

ITEM #064SFEH

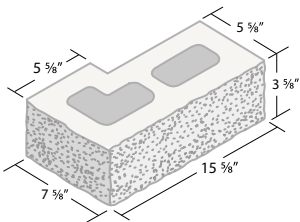

**6 x 4 x 16 Split
L-Return***

ITEM #064SL

ARCHITECTURAL UNITS: 8" Split Face

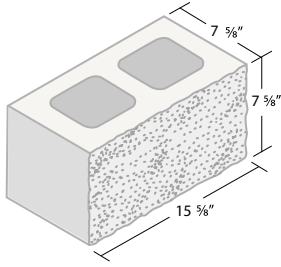

**8 x 8 x 16 Split
1 Face**
ITEM #088S

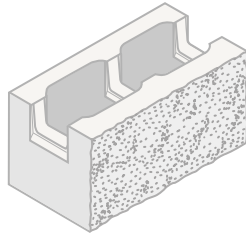

**8 x 8 x 16 Split
Bond Beam, 1 Face**
ITEM #088SK

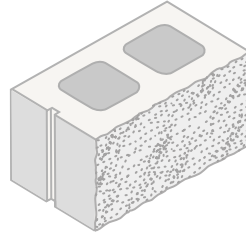

**8 x 8 x 16 Split
Jamb, 1 Face****
ITEM #088SJ

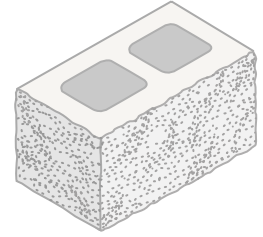

**8 x 8 x 16 Split
1 Face / 1 End**
ITEM #088SFE

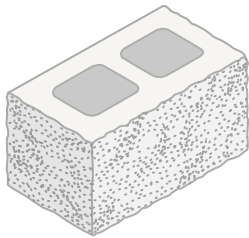

**8 x 8 x 16 Split
1 Face / 2 End***
ITEM #088SFEE

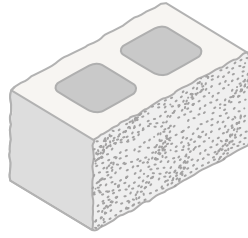

**8 x 8 x 16 Split
2 Face***
ITEM #088SFF

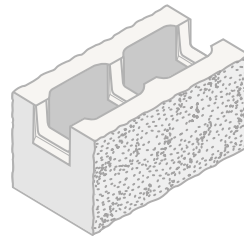

**8 x 8 x 16 Split
Bond Beam, 2 Face***
ITEM #088SFFK

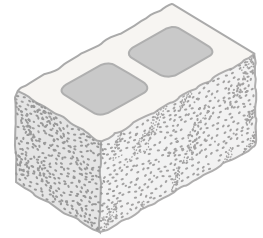

**8 x 8 x 16 Split
2 Face / 1 End***
ITEM #088SFFE

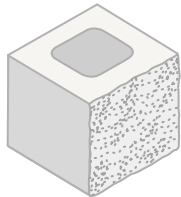

**8 x 8 x 8 Split
Half, 1 Face**
ITEM #088SH

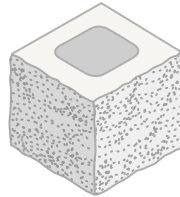

**8 x 8 x 8 Split
Half, 1 Face / 1 End**
ITEM #088SFEH

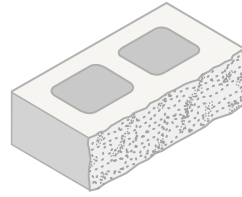

**8 x 4 x 16 Split
1 Face**
ITEM #084S

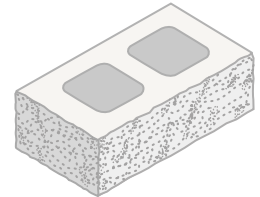

**8 x 4 x 16 Split
1 Face / 1 End**
ITEM #084SFE

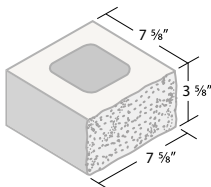

**8 x 4 x 8 Split
Half, 1 Face***
ITEM #084SH

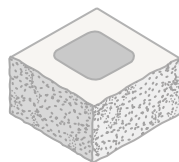

**8 x 4 x 8 Split
Half, 1 Face / 1 End***
ITEM #084SFEH

ARCHITECTURAL UNITS: 10" & 12" Split Face

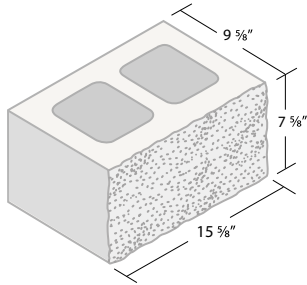

**10 x 8 x 16 Split
1 Face****
ITEM #108S

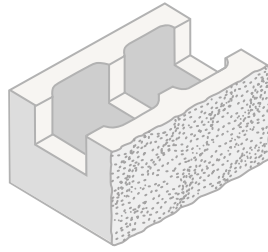

**10 x 8 x 16 Split
Bond Beam, 1 Face****
ITEM #108SK

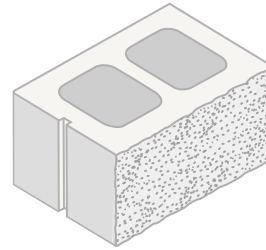

**10 x 8 x 16 Split
Jamb, 1 Face****
ITEM #108SJ

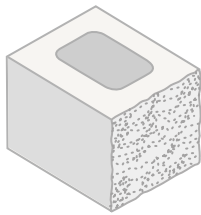

**10 x 8 x 8 Split
Half, 1 Face****
ITEM #108SH

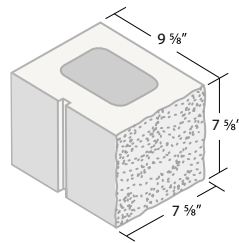

**10 x 8 x 8 Split
Jamb Half, 1 Face****
ITEM #108SJH

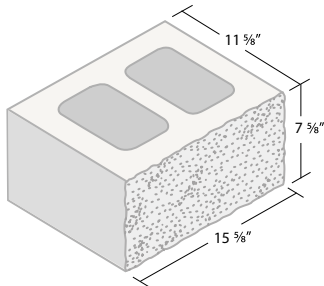

**12 x 8 x 16 Split
1 Face**
ITEM #128S

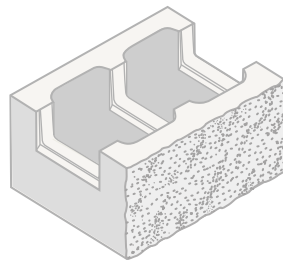

**12 x 8 x 16 Split
Bond Beam, 1 Face**
ITEM #128SK

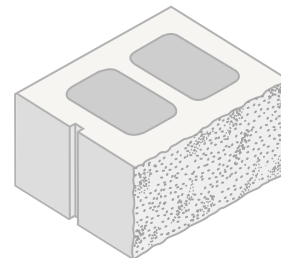

**12 x 8 x 16 Split
Jamb, 1 Face****
ITEM #128SJ

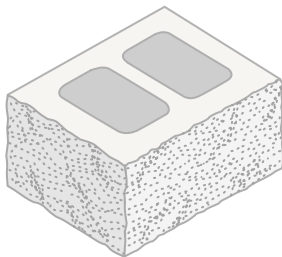

**12 x 8 x 16 Split
1 Face / 1 End****
ITEM #128S

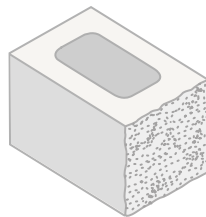

**12 x 8 x 8 Split
Half, 1 Face***
ITEM #128SH

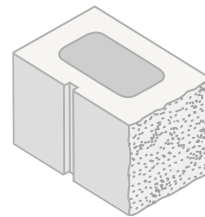

**12 x 8 x 8 Split
Jamb Half, 1 Face****
ITEM #128S

ARCHITECTURAL UNITS: 1-Score and 5-Score

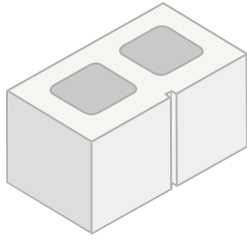

8 x 8 x 16 1-Score DSE
ITEM #0881GD

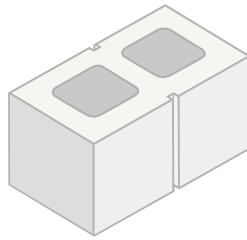

8 x 8 x 16 1-Score DSE, 2 Face**
ITEM #0881GFFD

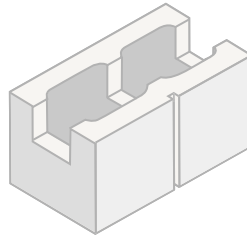

8 x 8 x 16 1-Score Bond Beam
ITEM #0881GK

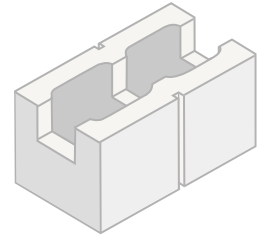

8 x 8 x 16 1-Score Bond Beam, 2 Face**
ITEM #0881GFFK

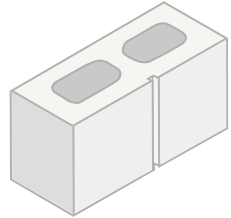

6 x 8 x 16 1-Score DSE**
ITEM #0681GD

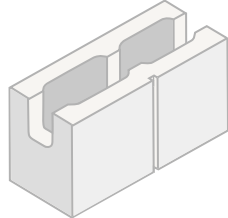

6 x 8 x 16 1-Score Bond Beam**
ITEM #0681GK

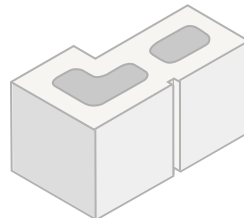

6 x 8 x 16 1-Score L-Return**
ITEM #0681GL

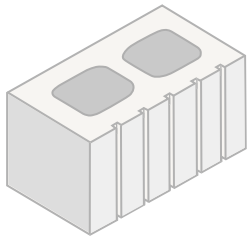

8 x 8 x 16 5-Score DSE
ITEM #0885GD

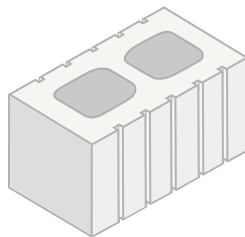

8 x 8 x 16 5-Score DSE, 2 Face**
ITEM #0885GFFD

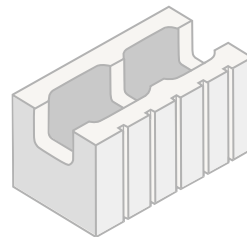

8 x 8 x 16 5-Score Bond Beam
ITEM #0885GK

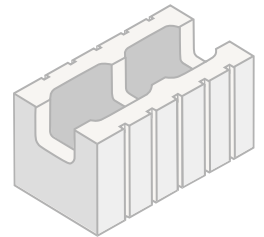

8 x 8 x 16 5-Score Bond Beam, 2 Face**
ITEM #0885GFFK

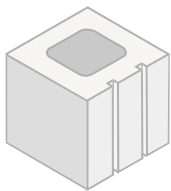

8 x 8 x 8 5-Score Half*
ITEM #0885GH

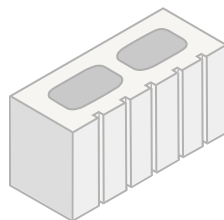

6 x 8 x 16 5-Score DSE**
ITEM #0685GD

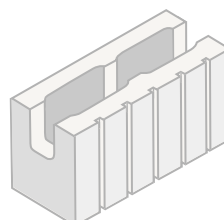

6 x 8 x 16 5-Score Bond Beam**
ITEM #0685GK

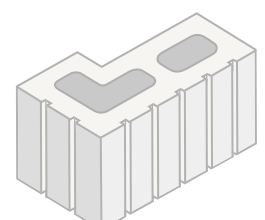

6 x 8 x 16 5-Score L-Return**
ITEM #0685GL



6 x 8 x 8 5-Score Half**
ITEM #0685GH

ARCHITECTURAL UNITS: Shadowcaster

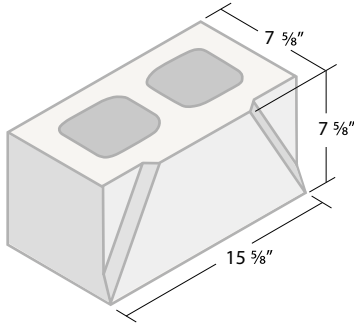

**8 x 8 x 16
Shadowcaster
Center***

ITEM #088SC

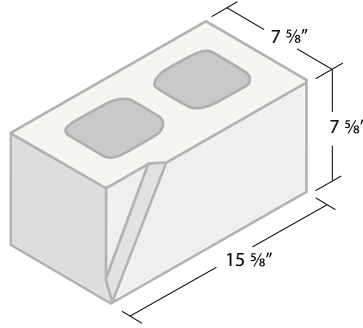

**8 x 8 x 16
Shadowcaster
Left***

ITEM #088SCL

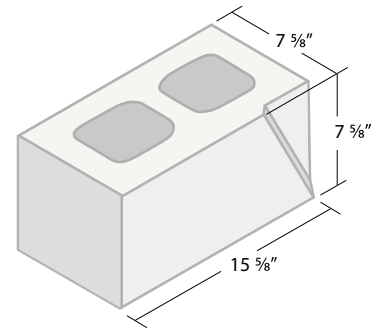

**8 x 8 x 16
Shadowcaster
Right***

ITEM #088SCR

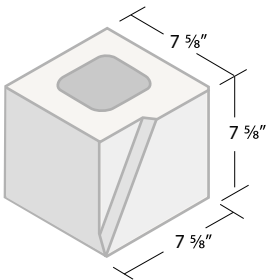

**8 x 8 x 8
Shadowcaster
Left Half***

ITEM #088SCLH

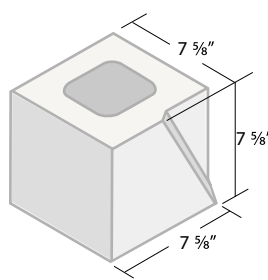

**8 x 8 x 8
Shadowcaster
Right Half***

ITEM #088SCRH

ARCHITECTURAL UNITS:

3-U Fluted Split Face

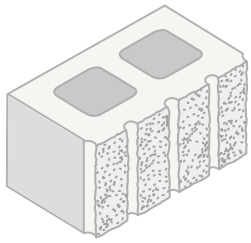

**8 x 8 x 16 3U
Fluted Split 1 Face****
ITEM #0883U

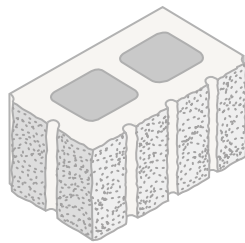

**8 x 8 x 16 3U Fluted
Split 1 Face / 1 End****
ITEM #0883UFE

3-V Fluted Split Face

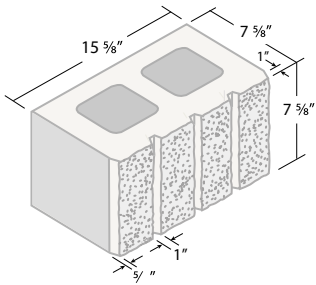

**8 x 8 x 16 3V Fluted
Split, 1 Face***
ITEM #0883V

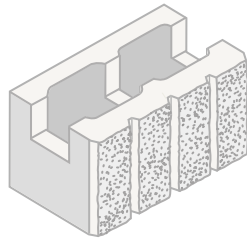

**8 x 8 x 16 3V Fluted Split
Bond Beam, 1 Face***
ITEM #0883VK

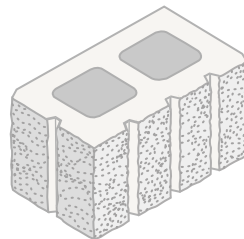

**8 x 8 x 16 3V Fluted Split
1 Face / 1 End***
ITEM #0883VFE

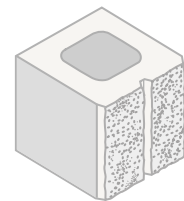

**8 x 8 x 8 3V Fluted Split
1 Face Half****
ITEM #0883VH

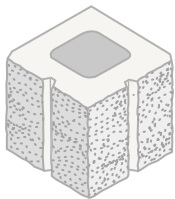

**8 x 8 x 8 3V Fluted Split
1 Face / 1 End Half****
ITEM #0883VFEH

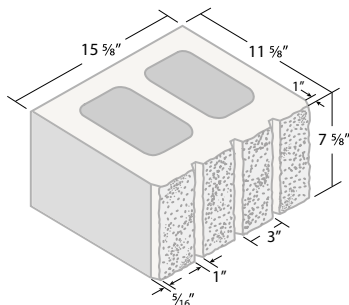

12 x 8 x 16 3V Fluted Split 1 Face**
ITEM #1283V

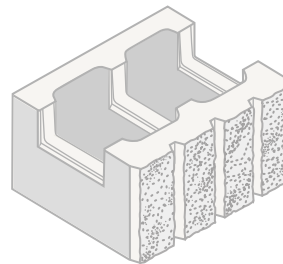

**12 x 8 x 16 3V Fluted Split
Bond Beam, 1 Face****
ITEM #1283VK

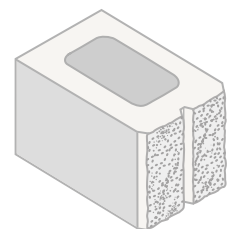

**12 x 8 x 8 3V Fluted
Split 1 Face Half****
ITEM #1283VH

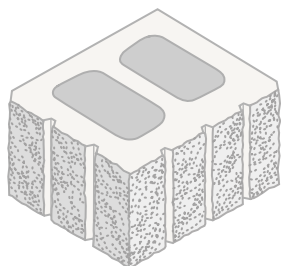

**12 x 8 x 16 3V Fluted Split
1 Face / 1 End****
ITEM #1283VFE

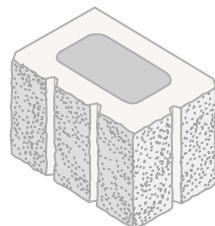

**12 x 8 x 8 3V Fluted
Split 1 Face / 1 End Half****
ITEM #1283VFEH

ARCHITECTURAL UNITS: 7-V Fluted Split Face

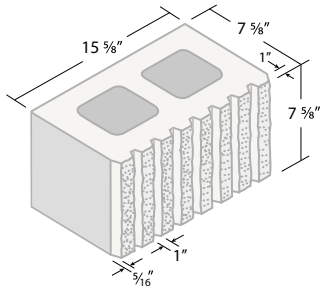

8 x 8 x 16 7V Fluted Split, 1 Face*
ITEM #0887V

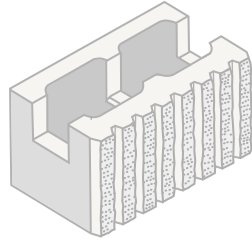

8 x 8 x 16 7V Fluted Split Bond Beam, 1 Face*
ITEM #0887VK

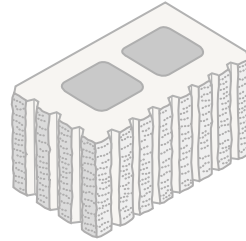

8 x 8 x 16 7V Fluted Split 1 Face / 1 End*
ITEM #0887VFE

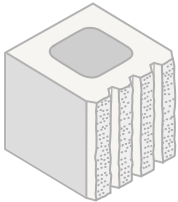

8 x 8 x 8 7V Fluted Split 1 Face Half**
ITEM #0887VH

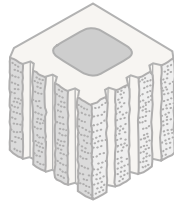

8 x 8 x 8 7V Fluted Split 1 Face / 1 End Half**
ITEM #0887VFEH

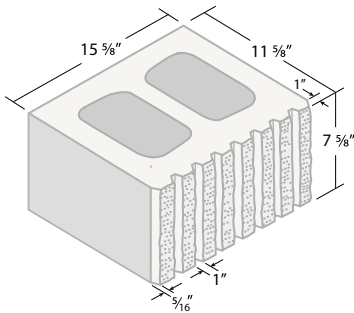

12 x 8 x 16 7V Fluted Split 1 Face**
ITEM #0887V

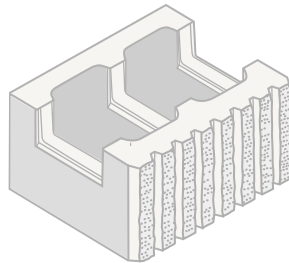

12 x 8 x 16 7V Fluted Split Bond Beam, 1 Face**
ITEM #0887V

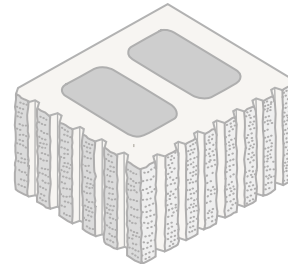

12 x 8 x 16 7V Fluted Split 1 Face / 1 End**
ITEM #0887VK

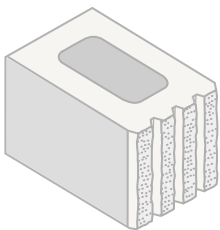

12 x 8 x 8 7V Fluted Split 1 Face Half**
ITEM #0887V

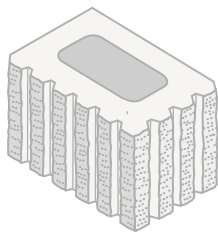

12 x 8 x 8 7V Fluted Split 1 Face / 1 End Half**
ITEM #0887VK

ARCHITECTURAL UNITS:

Tapestry

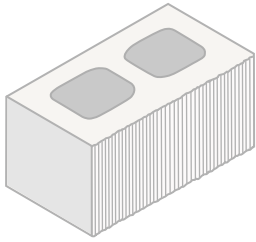

**8 x 8 x 16 Tapestry
1 Face****
ITEM #088T

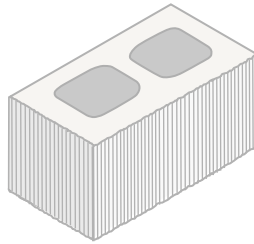

**8 x 8 x 16 Tapestry
1 Face / 1 End****
ITEM #088TFE

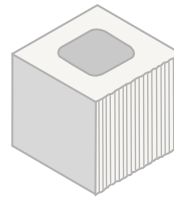

**8 x 8 x 8 Tapestry
Half, 1 Face****
ITEM #088TH

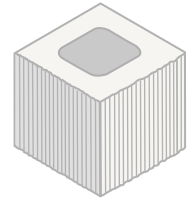

**8 x 8 x 8 Tapestry
Half, 1 Face / 1 End****
ITEM #088TFEH

Bullnose

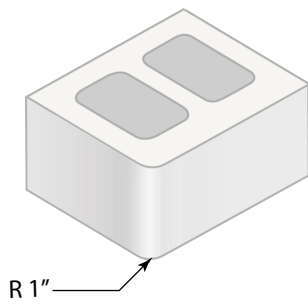

**12 x 8 x 16 Bullnose
1 Corner****
ITEM #128BNC

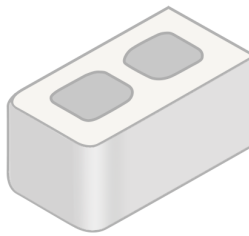

**8 x 8 x 16 Bullnose
1 End****
ITEM #088BNE

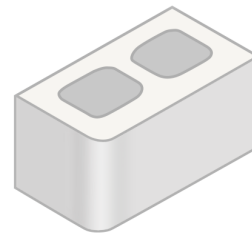

**8 x 8 x 16 Bullnose
1 Corner****
ITEM #088BNC

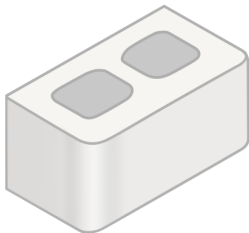

**8 x 8 x 16 Bullnose
1 Face***
ITEM #088BNF



**8 x 8 x 8 Bullnose
1 End Half***
ITEM #088BNEH

GROUND FACE Architectural Concrete Masonry Units

Also available in 4", 6", 10" and 12" units. Call our sales office for more information.

8 x 8 x 16 Ground Face Double Solid End

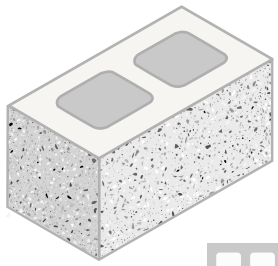

1 Face

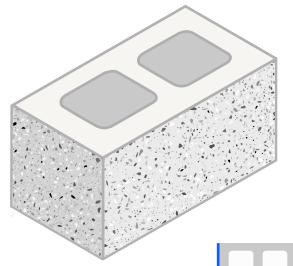

1 Face / 1 End

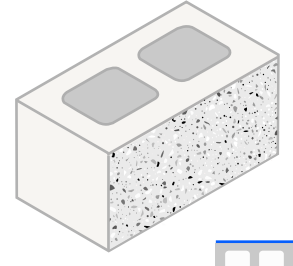

2 Face

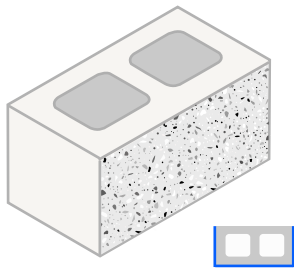

1 Face / 2 End

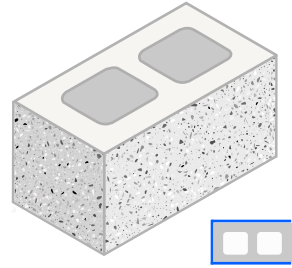

2 Face / 1 End

8 x 8 x 8 Ground Face Half

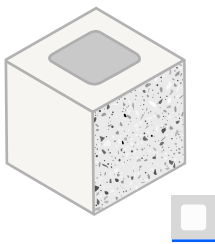

1 Face

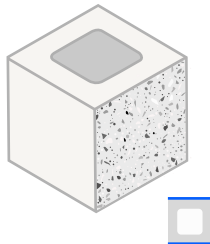

2 Face

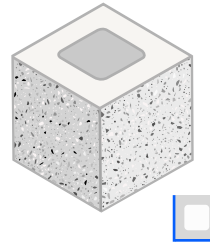

1 Face / 1 End

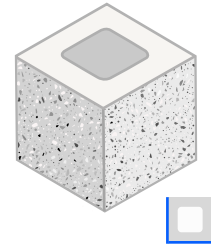

2 Face / 1 End

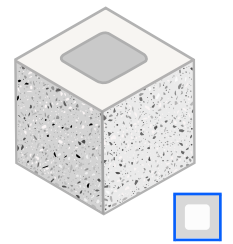

2 Face / 2 End

8 x 8 x 16 Ground Face Bond Beam

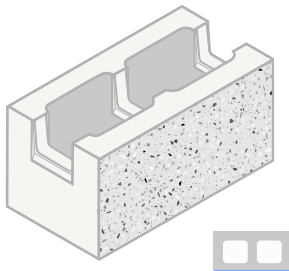

1 Face

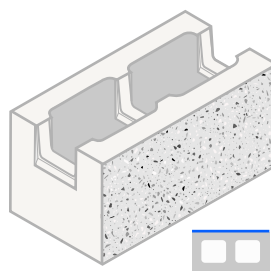

2 Face

GARDEN PRODUCTS

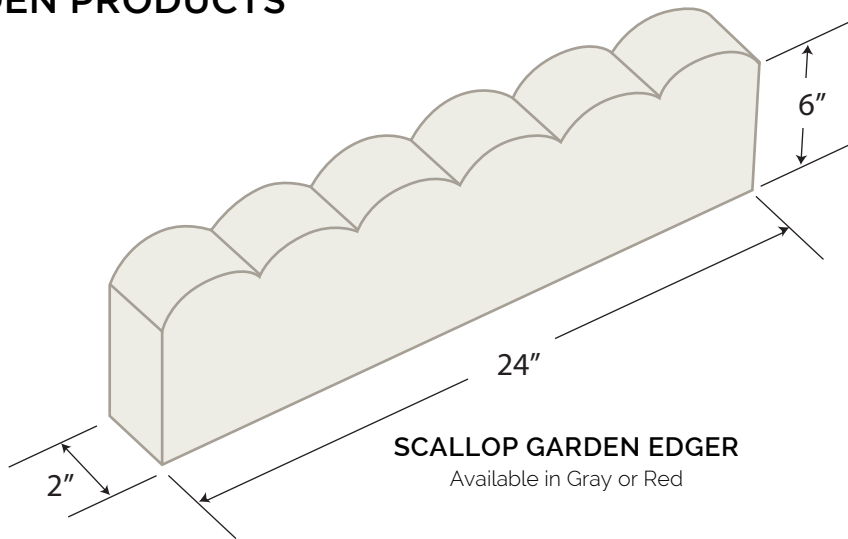

SCALLOP GARDEN EDGER
Available in Gray or Red

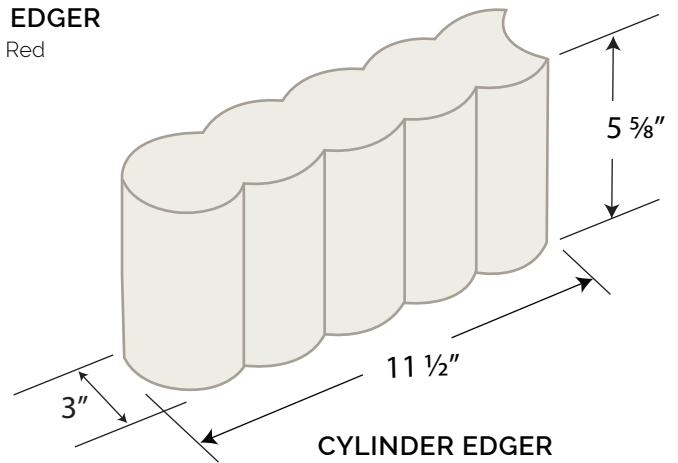

CYLINDER EDGER
Available in Gray or Red

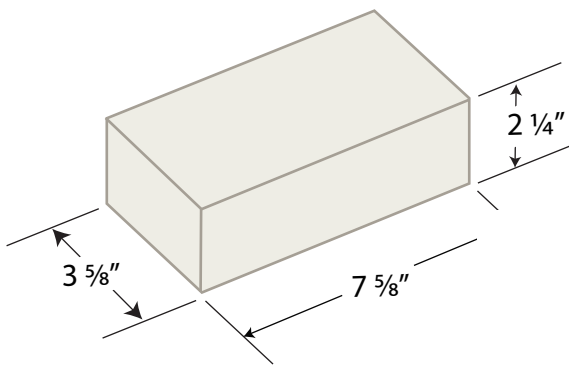

BRICK
Available in Buff, Red and Basalt

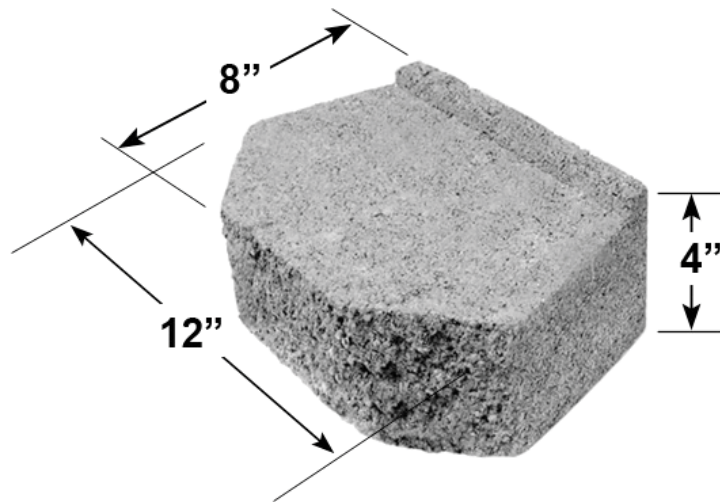

ARBORSTONE GARDEN WALL UNIT
Available in Tan, Rose and Dark Gray

GARDEN PRODUCTS

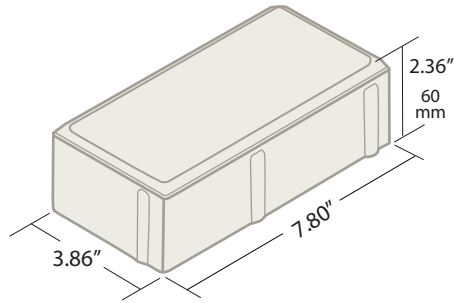
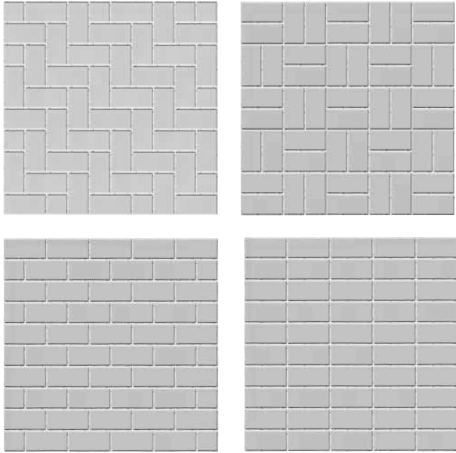

CLASSIC PAVER 60mm
(available in Gray, Red and Tan)

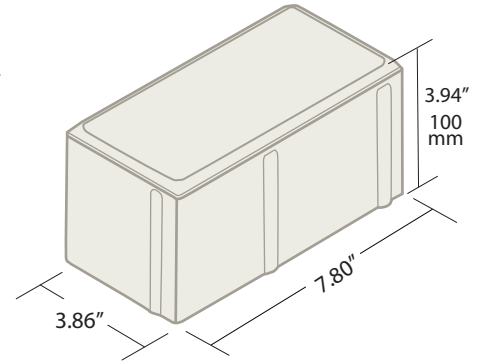

CLASSIC PAVER 100mm
(available in Gray, Red and Tan)

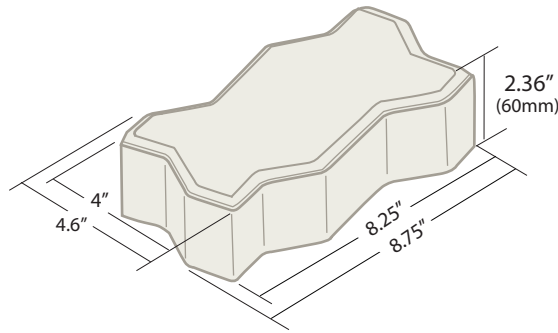
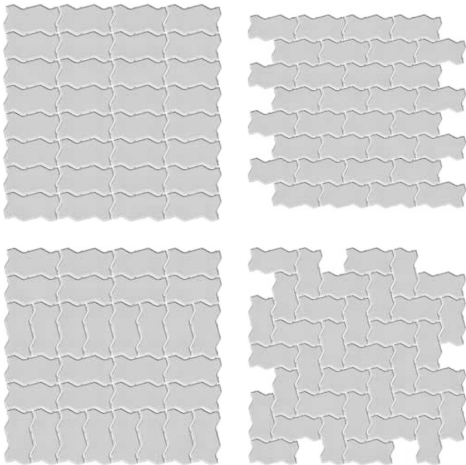

WAVE PAVER
(available in Gray, Red and Tan)

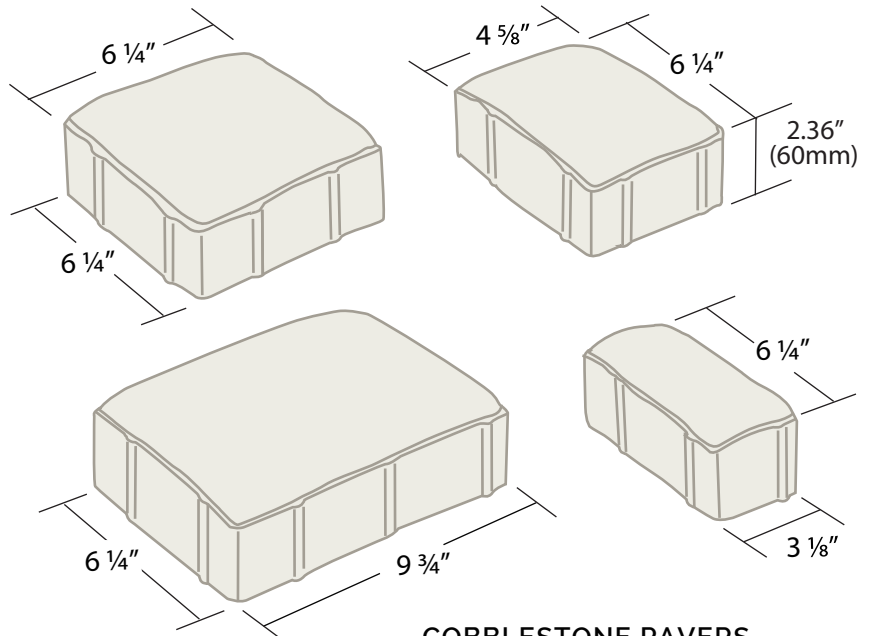
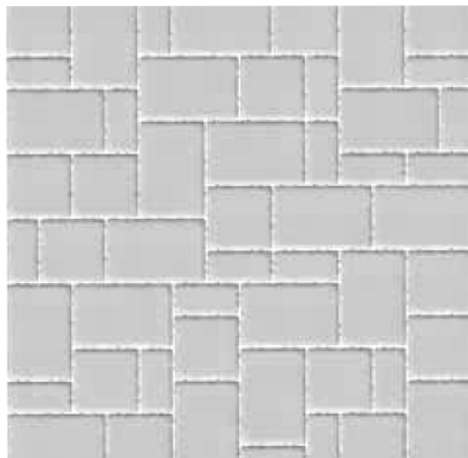

COBBLESTONE PAVERS
(available in Black, Gray, Red and Tan)

GARDEN PRODUCTS

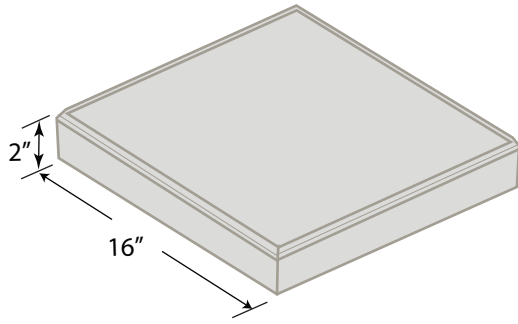

16" PATIO BLOCK SQUARE
available in Gray, Tan or Red

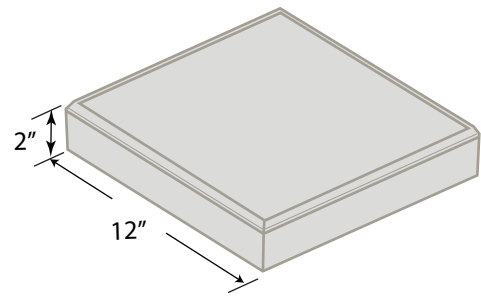

12" PATIO BLOCK SQUARE
available in Gray or Red

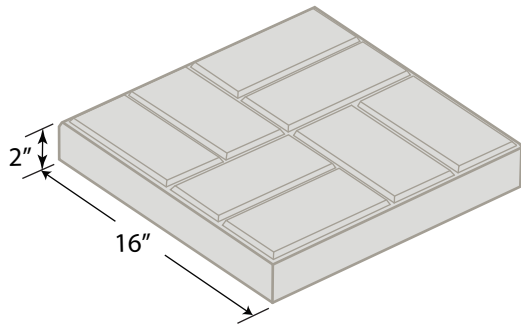

16" PATIO BLOCK SQUARE
Brick Pattern
available in Gray, Tan or Red

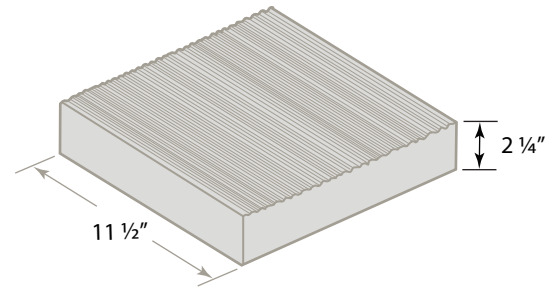

11.5" PATIO BLOCK SQUARE
Tapestry Pattern
available in Gray

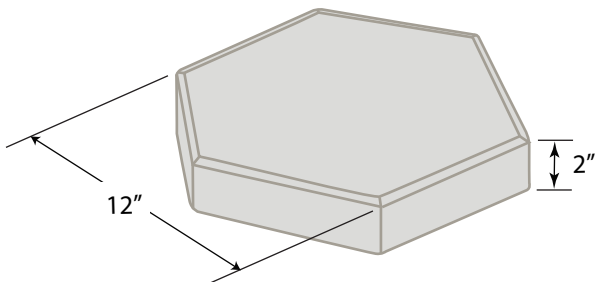

PATIO BLOCK HEXAGON
available in Gray or Red

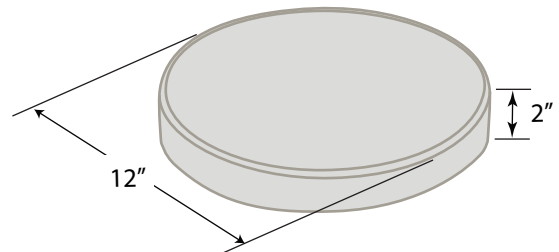

PATIO BLOCK CIRCLE
available in Gray or Red



SEGMENTAL RETAINING WALL UNITS

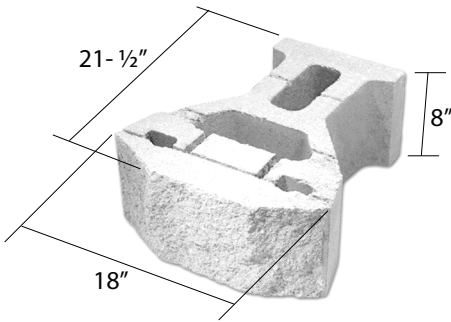

STANDARD I
Tri-plane Split Face
(available in Basalt or Limestone)

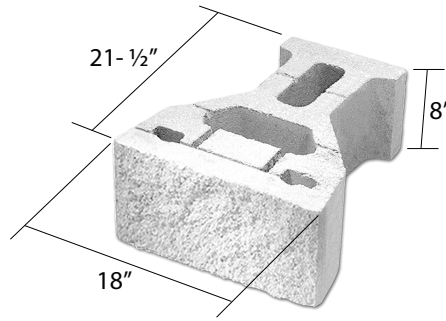

STANDARD I
Straight Split Face
(available in Basalt or Limestone)

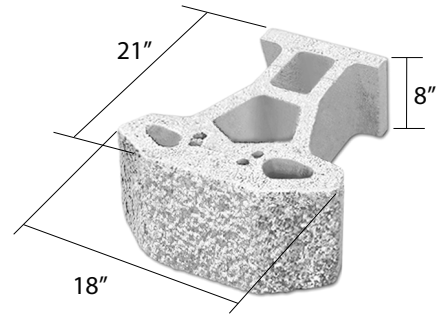

STANDARD III
Tri-plane Keycut Face
(available in Dark Gray, Tan, Rose, or Limestone Keycut)

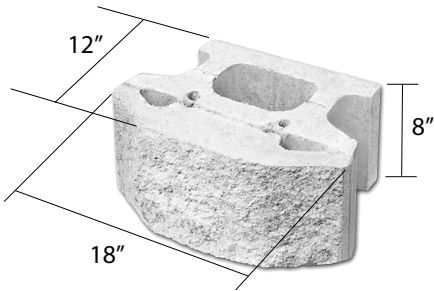

COMPAC I
Tri-plane Split Face
(available in Basalt or Limestone)

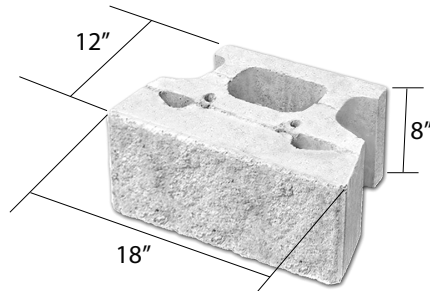

COMPAC I
Straight Split Face
(available in Basalt or Limestone)

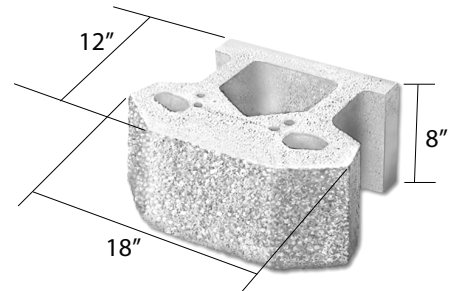

COMPAC III
Tri-plane Keycut Face
(available in Dark Gray, Tan, Rose, or Limestone Keycut)

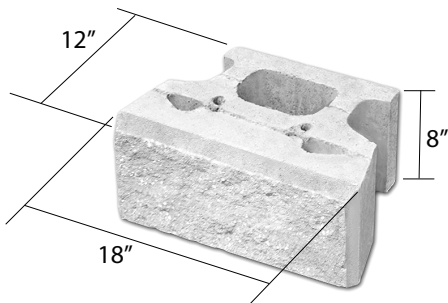

VICTORIAN
Straight Split Face
(available in Basalt or Limestone)

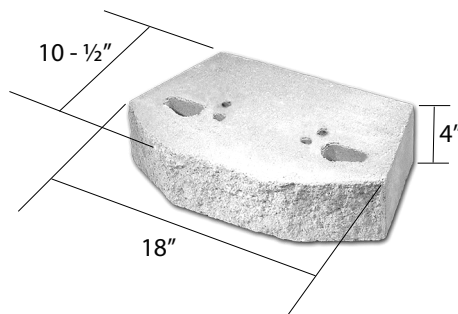

MINI
Tri-plane Split Face
(available in Basalt or Limestone)

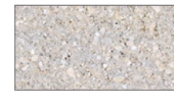

Limestone



Limestone KeyCut

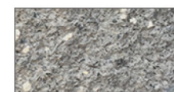

Basalt



Tan



Dark Gray



Rose

Keystone Caps

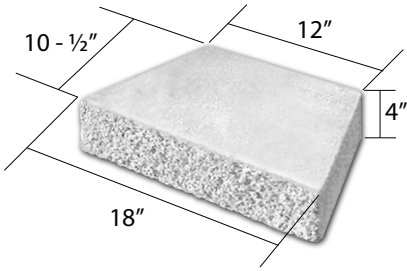

UNIVERSAL CAP
Straight Keycut Face
(available in Dark Gray, Tan, Rose, or Limestone Keykut)

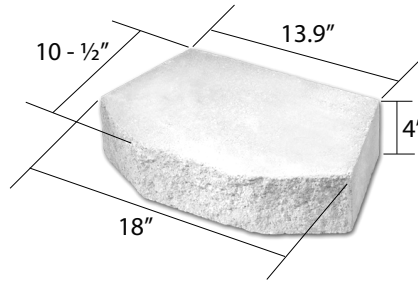

ANGLE CAP
Tri-plane Split Face
(available in Basalt or Limestone)

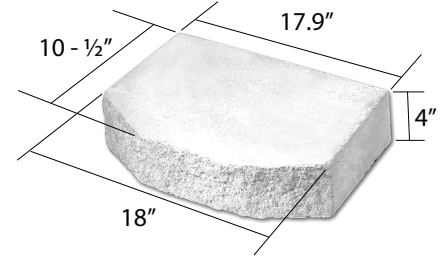

STRAIGHT CAP
Tri-plane Split Face
(available in Basalt or Limestone)

Keystone Corners

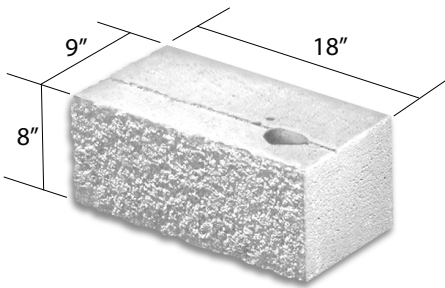

KEYKUT LEFT CORNER
Straight Keycut Face
(available in Dark Gray, Tan, Rose, or Limestone Keykut)

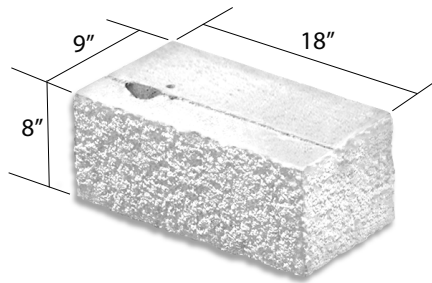

KEYKUT RIGHT CORNER
Straight Keycut Face
(available in Dark Gray, Tan, Rose, or Limestone Keykut)

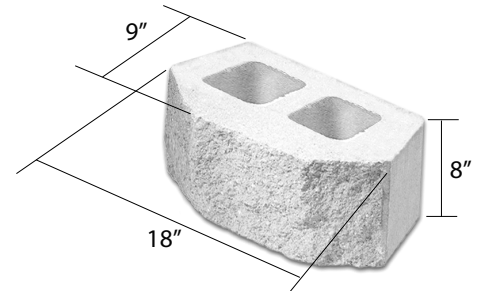

CORNER
Tri-plane Split Face
(available in Basalt or Limestone)



TILECO MORTARLESS BLOCK

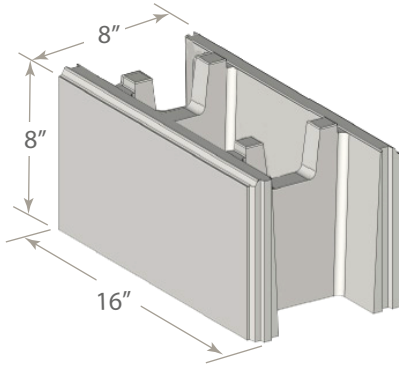

**Tileco Mortarless Block
Runner**
8 x 8 x 16
ITEM #H088R

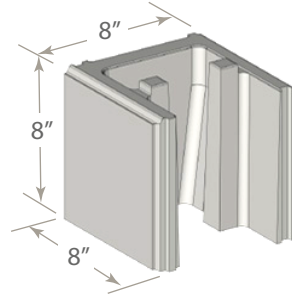

**Tileco Mortarless Block
Half**
8 x 8 x 8
ITEM #H088H

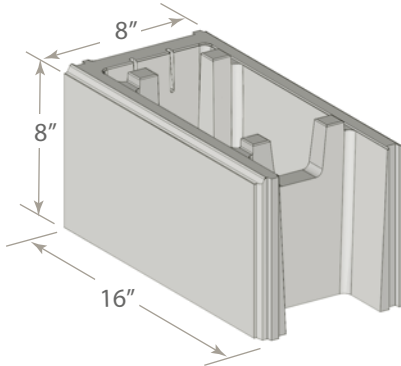

**Tileco Mortarless Block
End**
8 x 8 x 16
ITEM #H088E

SOLAR BALLAST BLOCK

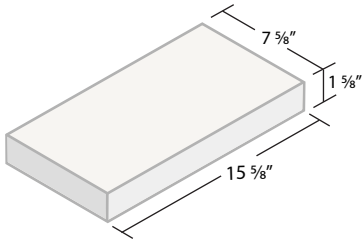

2 x 8 x 16 Ballast**

Weight: 14 lbs.
Units/Pallet: 288
ITEM #082BL

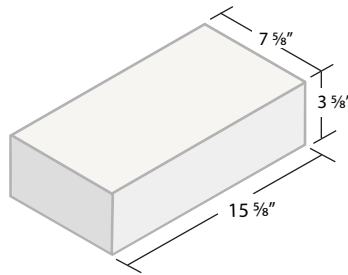

4 x 8 x 16 Ballast

Weight: 32 lbs.
Units/Pallet: 108
ITEM #048BL

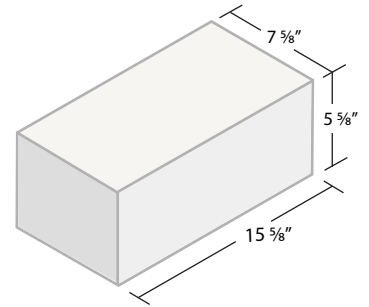

6 x 8 x 16 Ballast**

Weight: 48.5 lbs.
Units/Pallet: 72
ITEM #068BL

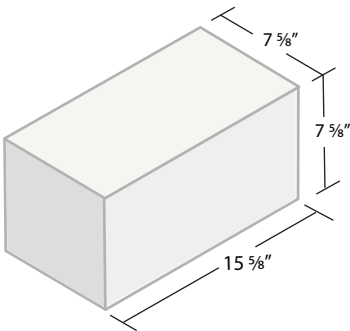

8 x 8 x 16 Ballast**

Weight: 65 lbs.
Units/Pallet: 54
ITEM #088BL

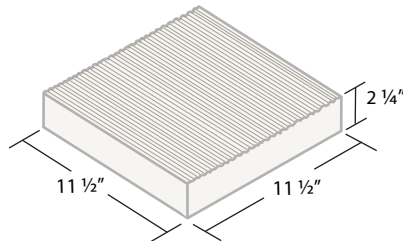

11-1/2" Square Ballast* with textured finish

Weight: 26 lbs.
Units/Pallet: 96
ITEM #PBT

* May require lead time. Call for availability.

** Special Order. Lead time and additional charges may apply.