

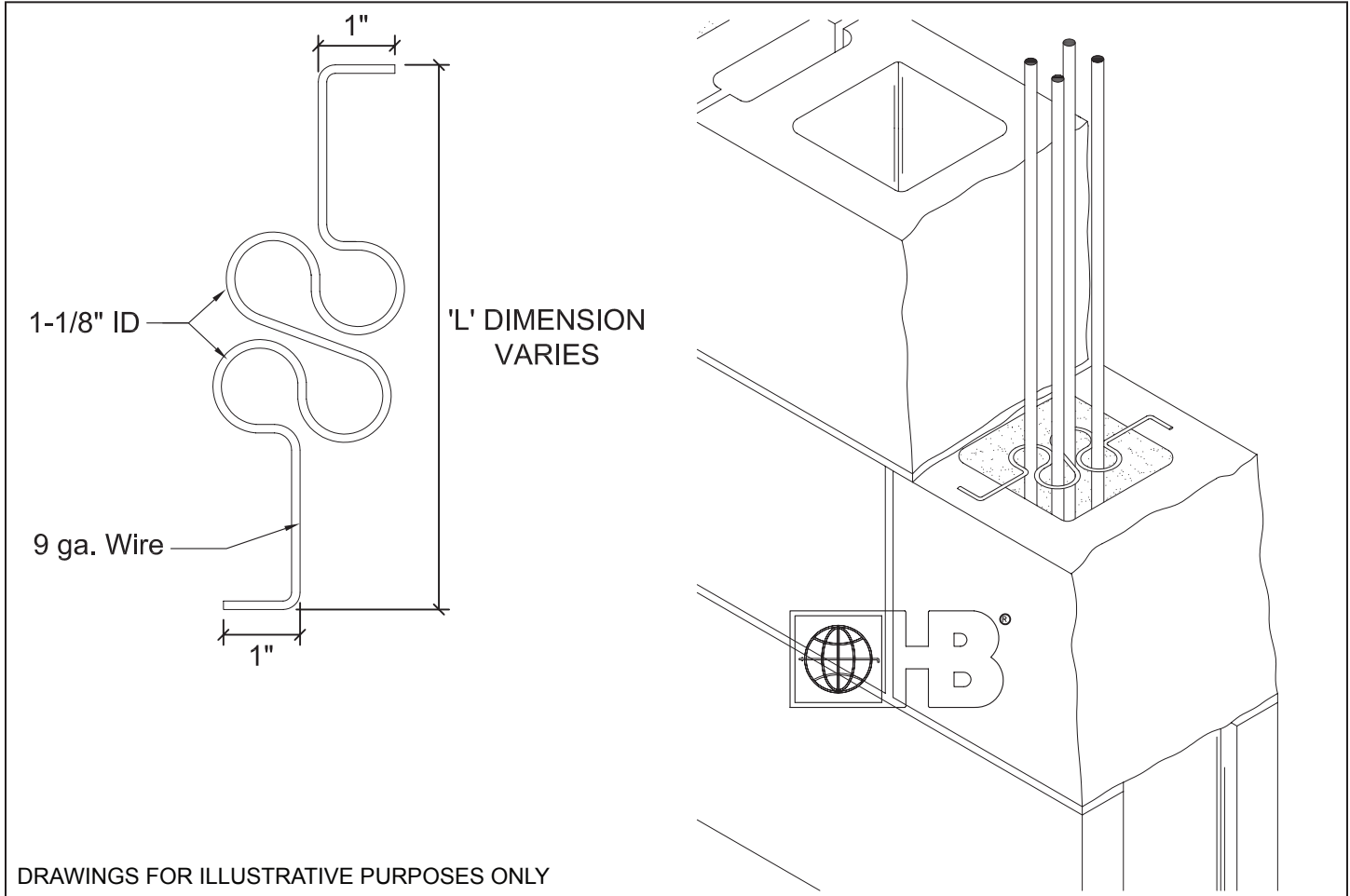

HOHMANN & BARNARD, INC.
A MiTek - BERKSHIRE HATHAWAY COMPANY

Rebar Positioners

RB - Twin Rebar Positioner



DRAWINGS FOR ILLUSTRATIVE PURPOSES ONLY

RB Rebar Positioner

For positioning rebar in center of block. The Z-shaped wire bridges cell of block while bends rest on shell.

Material Conformances:

Wire (Carbon Steel): Cold-drawn steel wire conforming to ASTM A1064/A1064M:

Tensile Strength - 80,000 p.s.i.

Yield Point - 70,000 p.s.i. minimum

Zinc coating:

Mill Galvanized: ASTM A641/A641M (0.1 oz/ft²)

Hot-Dip Galvanized after fabrication: ASTM A153/A153M-B2 (1.5 oz/ft)

Wire (Stainless Steel): ASTM A580/A580M - AISI Type 304 (Type 316 available on special order)

H&B manufactures steel wire products from a minimum of 95% recycled material.

Wire Diameter:

9 gauge (.148"Ø or W1.7)

Finishes:

- Mill Galvanized
- Hot-Dip Galvanized
- Stainless Steel

Note: H&B recommends Stainless Steel for maximum protection against corrosion.

Product# (size):

- RB-TWIN-6 (L=4" for 6" block)
- RB-TWIN-8 (L=6" for 8" block)
- RB-TWIN-10 (L=8" for 10" block)
- RB-TWIN-12 (L=10" for 12" block)

IMPORTANT: Since each construction project is unique, the appropriate selection and use of any product contained herein must be determined by competent architects, engineers and other appropriate professionals who are familiar with the specific requirements of the project in question.

HOHMANN & BARNARD, Inc.

30 Rasons Court | Hauppauge, NY 11788
CORPORATE HEADQUARTERS

T: 800.645.0616 F: 631.234.0683

www.h-b.com

Branch/Subsidiary Locations:

ALABAMA - ILLINOIS - MARYLAND

NEW YORK - PENNSYLVANIA - TEXAS

UTAH - CANADA

© HOHMANN & BARNARD, INC. - 2015